

User Guide

VT2442 Voice Gateway



Your Internet Telephone Service and 911

Caution!



IMPORTANT: When using this VT2442 voice gateway, you CANNOT make any calls, including an emergency call, and E911 location services WILL NOT be available, under the following circumstances:

- Your broadband Internet Service Provider (ISP) connection goes down, is lost, or otherwise fails
- You lose electrical power

When using this voice gateway, you may be able to make an emergency call to an operator, but E911 location services may not be available, under the following circumstances:

- You have changed the physical address of your voice gateway, and you did not update or otherwise advise Vonage of this change.
- You are using a non-U.S. telephone number.
- There are delays in making your location information available in or through the local automatic location information database.

Note: Vonage, not Motorola, is responsible for the provision of VoIP telephony services through this equipment. Motorola shall not be liable for, and expressly disclaims, any direct or indirect liabilities, damages, losses, claims, demands, actions, causes of action, risks or harms arising from or related to the services provided through this equipment.

For more information, go to <http://www.vonage.com/911>.

Cautions Related to Electrical Shock and Other Safety Concerns

WARNING: TO PREVENT FIRE OR SHOCK HAZARD, DO NOT EXPOSE THIS PRODUCT TO RAIN OR MOISTURE. THE UNIT MUST NOT BE EXPOSED TO DRIPPING OR SPLASHING. DO NOT PLACE OBJECTS FILLED WITH LIQUIDS, SUCH AS VASES, ON THE UNIT.

CAUTION: TO PREVENT ELECTRIC SHOCK, THIS EQUIPMENT MAY REQUIRE A GROUNDING CONDUCTOR IN THE LINE CORD. CONNECT THE UNIT TO A GROUNDING TYPE AC WALL OUTLET USING THE POWER CORD SUPPLIED WITH THE UNIT.

CAUTION: THIS PRODUCT WAS QUALIFIED UNDER TEST CONDITIONS THAT INCLUDED THE USE OF THE SUPPLIED CABLES BETWEEN SYSTEMS COMPONENTS. TO ENSURE REGULATORY AND SAFETY COMPLIANCE, USE ONLY THE PROVIDED POWER AND INTERFACE CABLES AND INSTALL THEM PROPERLY.

CAUTION: DIFFERENT TYPES OF CORD SETS MAY BE USED FOR CONNECTIONS TO THE MAIN SUPPLY CIRCUIT. USE ONLY A MAIN LINE CORD THAT COMPLIES WITH ALL APPLICABLE PRODUCT SAFETY REQUIREMENTS OF THE COUNTRY OF USE.

CAUTION: INSTALLATION OF THIS PRODUCT MUST BE IN ACCORDANCE WITH NATIONAL WIRING CODES AND CONFORM TO LOCAL REGULATIONS.

CAUTION: DO NOT OPEN THE UNIT. DO NOT PERFORM ANY SERVICING OTHER THAN THAT CONTAINED IN THE INSTALLATION AND TROUBLESHOOTING INSTRUCTIONS. REFER ALL SERVICING TO QUALIFIED SERVICE PERSONNEL.

CAUTION: CHANGES AND MODIFICATIONS NOT EXPRESSLY APPROVED BY MOTOROLA FOR COMPLIANCE COULD VOID USER'S AUTHORITY TO OPERATE THE EQUIPMENT.

IMPORTANT SAFETY INSTRUCTIONS — When using your telephone equipment, basic safety precautions should always be followed to reduce the risk of fire, electric shock, and injury to persons, including the following:

- Read all of the instructions listed here and/or in the user manual before you operate this equipment. Give particular attention to all safety precautions. Retain the instructions for future reference.
- This device must be installed and used in strict accordance with manufacturer's instructions as described in the user documentation that comes with the product.
- Comply with all warning and caution statements in the instructions. Observe all warning and caution symbols that are affixed to this equipment.
- Comply with all instructions that accompany this equipment.
- Do not overload outlets or extension cords, as this can result in a risk of fire or electric shock. Overloaded AC outlets, extension cords, frayed power cords, damaged or cracked wire insulation, and broken plugs are dangerous. They may result in a shock or fire hazard.
- Route power supply cords so that they are not likely to be walked on or pinched by items placed upon or against them. Pay particular attention to cords where they are attached to plugs and convenience receptacles, and examine the point where they exit from the product.
- Place this equipment in a location that is close enough to an electrical outlet to accommodate the length of the power cord.
- Place unit to allow for easy access when disconnecting the power cord of the device from the AC wall outlet.
- Do not connect the plug into an extension cord, receptacle, other outlet unless the plug can be fully inserted with no part of the blades exposed.
- Place this equipment on a stable surface.
- It is recommended that the customer install an AC surge protector in the AC outlet to which this device is connected. This is to avoid damaging the equipment by local lightning strikes and other electrical surges.
- Do not cover the device, or block the airflow to the device with any other objects. Keep the device away from excessive heat and humidity and keep the device free from vibration and dust.
- Wipe the unit with a clean, dry cloth. Never use cleaning fluid or similar chemicals. Do not spray cleaners directly on the unit or use forced air to remove dust.
- Operate this product only from the type of power source indicated on the product's marking label. If you are not sure of the type of power supplied to your home, consult your dealer or local power company.
- Do not use this product near water for example, near a bathtub, washbowl, kitchen sink or laundry tub, in a wet basement or near a swimming pool.
- Avoid using a telephone (other than a cordless type) during an electrical storm. There may be a remote risk of electric shock from lightning.
- Do not use the telephone to report a gas leak in the vicinity of the leak.
- Use only the power cord and batteries indicated in this manual. Do not dispose of batteries in a fire. They may explode. Check with local codes for possible special disposal instructions.
- CAUTION: To reduce the risk of fire, use only No. 26 AWG or larger (e.g., 24 AWG) UL Listed or CSA Certified Telecommunication Line Cord.
- Disconnect TNV circuit connector(s) before disconnecting power.
- Disconnect TNV circuit connector before removing cover.
- Upon completion of any service or repairs to this product, ask the service technician to perform safety checks to determine that the product is in safe operating condition.
- SAVE THESE INSTRUCTIONS

FCC Compliance Class B Digital Device

This device complies with part 15 of the FCC Rules. Operation is subject to the following two conditions: (1) This device may not cause harmful interference, and (2) This device must accept any interference received, including interference that may cause undesired operation.

Note: This equipment has been tested and found to comply with the limits for a Class B digital device, pursuant to part 15 of the FCC Rules. These limits are designed to provide reasonable protection against harmful interference when the equipment is operated in a residential environment. This equipment generates, uses and can radiate radio frequency energy and, if not installed and used in accordance with the instructions, may cause harmful interference to radio communications. However, there is no guarantee that interference will not occur in a particular installation. If this equipment does cause harmful interference to radio or television reception, which can be determined by turning the equipment off and on, the user is encouraged to try to correct the interference by one or more of the following measures:

- Reorient or relocate the receiving antenna.
- Increase the separation between the equipment and receiver.
- Connect the equipment into an outlet on a circuit different from that to which the receiver is connected.
- Consult the dealer or an experienced radio/TV technician for help.

Changes or modification not expressly approved by the party responsible for compliance could void the user's authority to operate the equipment.

Canadian Compliance

This Class B digital device complies with Canadian ICES-003.

Cet appareil numérique de la classe B est conforme à la norme NMB-003 du Canada.

Regulatory, Safety, Software License, and Warranty Information Card

This product is provided with a separate *Regulatory, Safety, Software License, and Warranty Information* card.

THIS PRODUCT IS IN COMPLIANCE WITH ONE OR MORE OF THE STANDARDS LISTED ON THE REGULATORY, SAFETY, SOFTWARE LICENSE, AND WARRANTY INFORMATION CARD. NOT ALL STANDARDS APPLY TO ALL MODELS.

NO WARRANTIES OF ANY KIND ARE PROVIDED BY MOTOROLA WITH RESPECT TO THIS PRODUCT, EXCEPT AS STATED ON THE REGULATORY, SAFETY, SOFTWARE LICENSE, AND WARRANTY INFORMATION CARD. MOTOROLA'S WARRANTIES DO NOT APPLY TO PRODUCT THAT HAS BEEN REFURBISHED, RECONDITIONED, OR REISSUED BY YOUR SERVICE PROVIDER.

Copyright © 2006 by Motorola, Inc.

All rights reserved. No part of this publication may be reproduced in any form or by any means or used to make any derivative work (such as translation, transformation or adaptation) without written permission from Motorola, Inc.

Motorola reserves the right to revise this publication and to make changes in content from time to time without obligation on the part of Motorola to provide notification of such revision or change. Motorola provides this guide without warranty of any kind, either implied or expressed, including, but not limited to, the implied warranties of merchantability and fitness for a particular purpose. Motorola may make improvements or changes in the product(s) described in this manual at any time.

MOTOROLA and the Stylized M Logo are registered in the US Patent & Trademark Office. Vonage, The Broadband Phone Company, and Vonage Digital Voice are registered service marks owned and used under license from Vonage Marketing, Inc., a wholly owned subsidiary of Vonage Holdings Corp. Microsoft, Windows, Windows Me, and Windows NT are either trademarks or registered trademarks of Microsoft Corporation in the U.S and/or other countries. Microsoft Windows screen shots are used by permission of Microsoft Corporation. Macintosh is a registered trademark of Apple Computer, Inc. Linux is a registered trademark of Linus Torvalds. Adobe and Reader are registered trademarks of Adobe Systems, Incorporated in the United States and other countries. Netscape and Navigator are registered trademarks of Netscape Communications Corporation. UNIX is a registered trademark of the Open Group in the United States and other countries. Firefox is a registered trademark of the Mozilla Foundation. DOCSIS is a registered trademark of Cable Television Laboratories, Inc. All other product or service names are the property of their respective owners.

Contents

Overview	1
Features	1
Sample Wired Home or Small-Office Network	2
Front Panel	3
Rear Panel	4
Installation	5
Before You Begin	5
Precautions	6
Gather Information	6
Connect the VT2442	6
Installation With an Existing Router	7
Installation With a Standard Modem	9
Connecting Your Telephone	11
Basic Configuration	12
Logging In to the VT2442	13
Configuration Overview	14
Exporting the VT2442 Configuration	14
Importing the Saved Configuration	14
Restarting the VT2442	15
Logging Out	15
WAN Configuration	16
WAN Setup for PPPoE (DSL)	17
WAN Setup for a Static IP Address (Cable Modem)	18
WAN Setup for DHCP (Cable Modem)	19
LAN Configuration	20
Advanced Configuration	22
ADVANCED	22
UPnP	23
IP QoS	24
IP QoS Traffic Rule	25
Port Forwarding	27
Custom Port Forwarding	29
DMZ Settings	30
IP Filters	31
Custom IP Filters	32
LAN Clients	33
Web Filters	34
Dynamic DNS Client	35
Multicast	36
Static Routing	37
Dynamic Routing	38
Remote Web Access	39



Remote SSH Access	40
Ethernet Switch	41
TOOLS	42
Restore Defaults	42
Import/Export Configuration	43
Remote Log – Router	44
User Management	45
Ping Test	46
Restart	47
STATUS	48
Network Statistics	48
Connection Status	49
DDNS Update Status	50
DHCP Clients	51
Product Information	51
System Log – Router	52
Configuring TCP/IP	53
Configuring TCP/IP in Windows 95, Windows 98, or Windows Me	53
Configuring TCP/IP in Windows 2000	56
Configuring TCP/IP in Windows XP	59
Verifying the IP Address in Windows 95, Windows 98, or Windows Me	63
Verifying the IP Address in Windows 2000 or Windows XP	64
Troubleshooting	65
Resetting All of Your Equipment	66
Replacing an Existing Router with the VT2442	66
Contact Us	68
Frequently Asked Questions	69
Glossary	70
Software License	74

Overview

The VT2442 Voice Gateway enables up to two standard analog telephones to use digital telephony services over a [broadband](#) Internet connection. The broadband connection can be any high-speed data service through either:

- A cable modem connected to coaxial cable from a cable television company
- A DSL (digital subscriber line) modem connected to telephone wiring from a telephone company



The VT2442 provides four [Ethernet](#) ports and a built-in [router](#) for a home or small office local area network ([LAN](#)). It is ideal for your home, home office, or small business/enterprise.

You can connect up to four computers or other Ethernet devices directly to the VT2442. By adding [hubs](#) or other routers, you can expand your network up to the recommended maximum of 16 connected devices.

The computers on the VT2442 network must:

- Have a 10Base-T or 10/100Base-T Ethernet adapter
- Be running Microsoft® Windows®, Macintosh® OS, Linux®, or UNIX®

Features

The VT2442 Voice Gateway provides:

- Up to two lines of robust, full-featured telephone and fax service
- Voice-over-data prioritization so you can speak on the phone while using the Internet with no reduction in voice quality
- Full network connectivity in a single unit, eliminating the cost and clutter of stand-alone routers and hubs
- VPN passthrough support for remote access to enterprise applications
- Portability to plug into any broadband connection (cable or DSL)
- Plug-and-play installation
- Compact, low-profile design
- Easy Web-based configuration (see "[Basic Configuration](#)" on page 12)
- Support for features such as caller ID, call waiting, three-way calling, and call forwarding
- Firewall to help protect your network against external attacks

Sample Wired Home or Small-Office Network

The VT2442 Voice Gateway provides advanced routing and four Ethernet ports, enabling you to connect up to four computers without a separate hub or router:

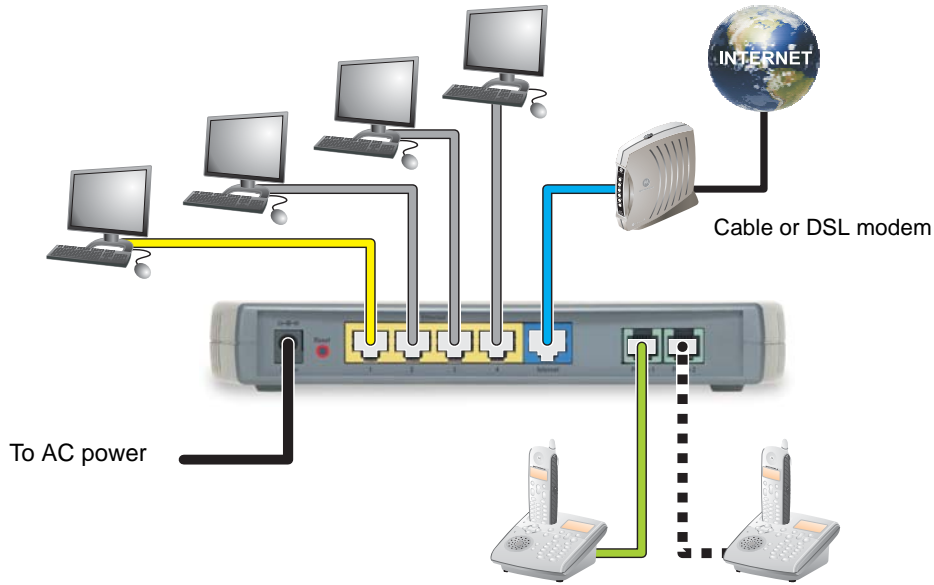

If you connect the VT2442 directly to your cable or DSL modem, it can prioritize voice calls over data traffic to help ensure high-quality phone service.

Front Panel

The front panel provides the following lights:

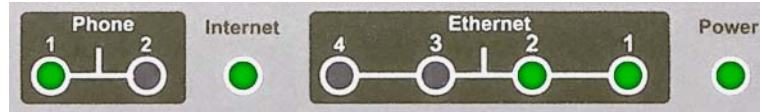

Light

Description

- Phone 1, 2** Indicates the status of phone line one and optional line two, respectively:
- Solid green — The phone for that line is on hook, registered with Vonage, and ready for use.
 - Blinking green — The phone for that line is ringing or off hook.
 - Blinking orange — You have voice mail.
 - Both blinking rapidly in unison with the **Power** light — The voice gateway is downloading a firmware upgrade from Vonage. *Please do not unplug or disconnect your voice gateway while it is downloading firmware.*
 - Off — The phone line is not registered for Vonage service. You cannot use it for phone calls.
- Internet** Indicates the Internet connection speed:
- Solid green — 100Base-T
 - Solid yellow — 10Base-T
- Flashes when there is activity on the Internet connection.
- Ethernet 1, 2, 3, 4** Indicates the speed of the respective Ethernet connection:
- Solid green — 100Base-T
 - Solid yellow — 10Base-T
- Flashes when there is activity on the respective Ethernet connection.
- Power** *If it is ever red — blinking or solid — restart the voice gateway (see “Restarting the VT2442” on page 15).*
- During a normal start-up, it lights in the following sequence:
- Blinking once — You have turned the voice gateway on by plugging it in to AC power.
 - Blinking twice — The voice gateway is retrieving its [IP address](#).
 - Blinking three times — The voice gateway is [downloading](#) its configuration file from Vonage.
 - Blinking four times — The voice gateway is connecting to the Vonage [server](#).
 - (Optional) Blinking rapidly in unison with the **Phone 1** and **2** lights — The voice gateway is downloading a firmware upgrade from Vonage. *Please do not unplug or disconnect your voice gateway while it is downloading firmware.*
 - Solid green — The voice gateway has successfully registered with Vonage. If a firmware upgrade was needed, it has been successfully completed.

Rear Panel

The rear panel provides the following ports:

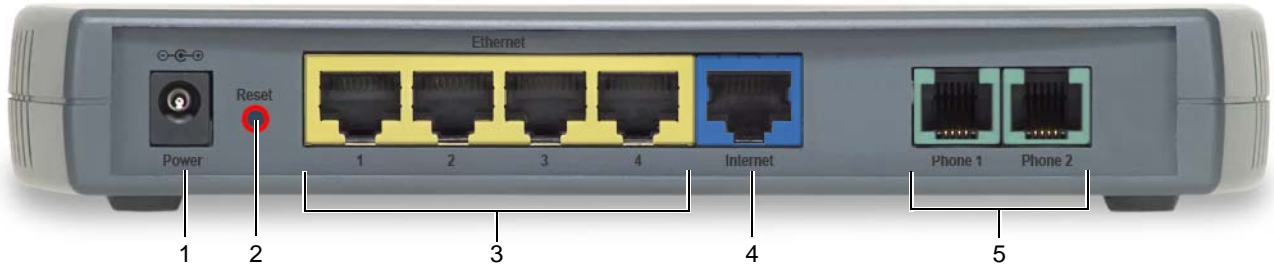

Key	Item	Description
1	Power	Connector for a 12 V adapter that you plug into an AC power outlet
2	Reset	Press to restart the VT2442; you can also restart your voice gateway using its graphical user interface (GUI) as described in "Restarting the VT2442" on page 15
3	Ethernet 1, 2, 3, 4	Yellow Ethernet ports for up to four computers, gaming machines, printers, or other devices you can connect to an Ethernet network
4	Internet	Blue Ethernet port to your cable or DSL modem
5	Phone 1 and 2	Green ports for phones one and two (optional). If you subscribe to only one phone line from Vonage, you must connect your phone to the Phone 1 port.

❖ Installation

To install your VT2442, you need to:

- Review “[Before You Begin](#)” on page 5 and “[Precautions](#)” on page 6
- [Gather Information](#) (see page 6)
- [Connect the VT2442](#) (see page 6)

Before You Begin

Before you begin installation, check that you received the following items with your VT2442:

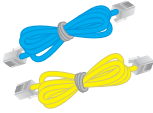
Item	Description
AC adapter 	Connects the VT2442 to an AC electrical outlet
Ethernet cables 	Blue cable connects the Internet port on your VT2442 to your cable or DSL modem Yellow cable connects an Ethernet port on your VT2442 to a computer or other network device
Vertical mounting stand	Provides vertical mounting on a desktop or other flat surface to use less space
VT2442 Voice Gateway Quick Start Guide	Provides instructions to quickly set up and configure your voice gateway

In addition to your VT2442 voice gateway, you also need:

- An established DSL or cable Internet connection
- One or two touch-tone telephones
- One or more computers with these minimum requirements:
 - Pentium-class processor or faster
 - 16 MB of memory
 - 10 MB of hard disk space available
 - Windows® 98, Windows 98 SE, Windows Me®, Windows NT®, Windows XP™
- A 10/100Base-T category 3 or better straight-through Ethernet cable with RJ-45 terminators for each computer to be wired to the network (the yellow cable provided with the voice gateway connects one computer)

*If you purchased your VT2442 voice gateway from a retail location, you must first activate your Vonage® Phone Service. You will need to provide the **WAN MAC ID** on the bottom of the VT2442.*

- In the USA, visit www.vonage.com/activate

Precautions

Postpone installation until there is no risk of thunderstorm or lightning activity in the area.

To prevent overheating the VT2442, do not block the ventilation holes on the unit.

Do not open the VT2442. *Refer all service to Vonage.*

Be sure you read and understand “[Your Internet Telephone Service and 911](#)” and “[Cautions Related to Electrical Shock and Other Safety Concerns](#)” on page ii.

Caution!



We recommend powering your VT2442 through a surge protector or universal power supply (UPS).

Gather Information

You may need to obtain the following information about your high-speed Internet connection:

- For a DSL connection *only*, your user name and password
- For a cable modem connection using [static IP addresses](#) *only*, your [IP address](#), [subnet mask](#), [default gateway](#), and [DNS server IP address](#) or addresses

If you already have a router, we recommend printing its configuration screens to use for reference during [Basic Configuration](#).

Connect the VT2442

- If you already have a router, use instructions [A: Installation With an Existing Router](#) (see page 7).

If you have more than one computer connected to a single Internet connection, you have a router.

- If your cable or DSL modem has a built-in router with multiple computers connected, you should also use instructions [A](#).

Some cable data and DSL providers supply modems containing a router. If your modem has multiple Ethernet ports, it probably contains a router. If you are not sure, call your cable or DSL provider and ask them whether your modem contains a router.

- If you have a standard cable or DSL modem with just *one* computer connected, use instructions [B: Installation With a Standard Modem](#) (see page 9).

You can place the VT2442 on a flat surface horizontally or vertically. For vertical installation, insert the voice gateway into the supplied base stand. The voice gateway slides snugly into a notch in the stand to keep it stable.

A Installation With an Existing Router

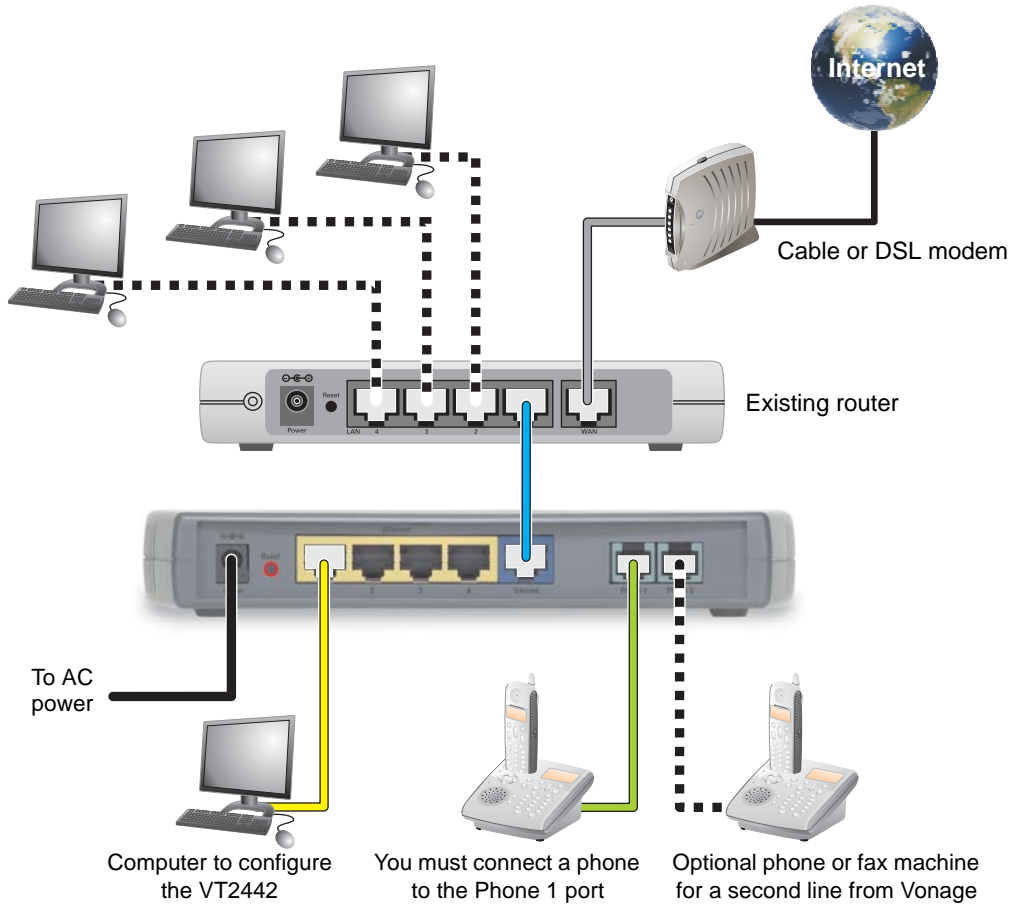

- 1 Unplug your cable or DSL modem power cord or adapter.
- 2 Unplug your router power cord or adapter. Please leave your modem and router connected to the cable or phone line that provides your Internet connection.
- 3 Disconnect one computer from your router.
- 4 Connect one end of the blue Ethernet cable to an Ethernet port on your router.
- 5 Connect the other end of the blue Ethernet cable to the blue Ethernet port labeled **Internet** on the rear panel of your voice gateway.
- 6 Connect one end of the yellow Ethernet cable to the **Ethernet 1** port on your voice gateway.
- 7 Connect the other end of the yellow Ethernet cable to the Ethernet port on the computer you disconnected in step 3.

- 8 Plug your cable or DSL modem power cord or adapter into an AC power outlet. Refer to the instructions provided with the modem.

IMPORTANT: Before you continue, be sure to allow enough time for your modem to complete its start-up process. Refer to the information provided by the modem manufacturer. For example, startup for a Motorola SURFboard cable modem is complete when its Power, Receive, Send, and Online lights are on and no longer flashing.

- 9 Plug your router power cord or adapter into an AC power outlet. Be sure to allow enough time for your modem to complete its start-up process. Refer to the instructions provided with the router.

- 10 Connect the power adapter supplied with your voice gateway to the **Power** connector on its rear panel.

- 11 Plug the other end into an AC power outlet.

This turns on your voice gateway. The VT2442 does not have an On/Off power switch. The Power light on the front panel performs a series of blinks as described in “Front Panel” on page 3. You should not unplug your voice gateway when it is not in use.

IMPORTANT: Before you continue, be sure to allow enough time for your voice gateway to complete its start-up process. VT2442 startup is complete when the Power light on its front panel lights solid green. This usually takes a few minutes.

We recommend plugging the VT2442 power adapter into an electrical outlet that is grounded and equipped with a surge protector or UPS.

- 12 Turn on your computer. The Ethernet 1 light on the VT2442 front panel should light.

IMPORTANT: Before you continue, be sure the VT2442 Power, Ethernet 1, and Internet lights are all on.

- 13 On your computer, open a Web browser such as Microsoft Internet Explorer, Netscape Navigator[®], or Mozilla Firefox[®].

- 14 Check your Internet connection by visiting any website.

If your Internet connection does not work, see “[Troubleshooting](#)” on page 65.

If your Internet connection works, go to [C “Connecting Your Telephone”](#) on page 11.

B Installation With a Standard Modem

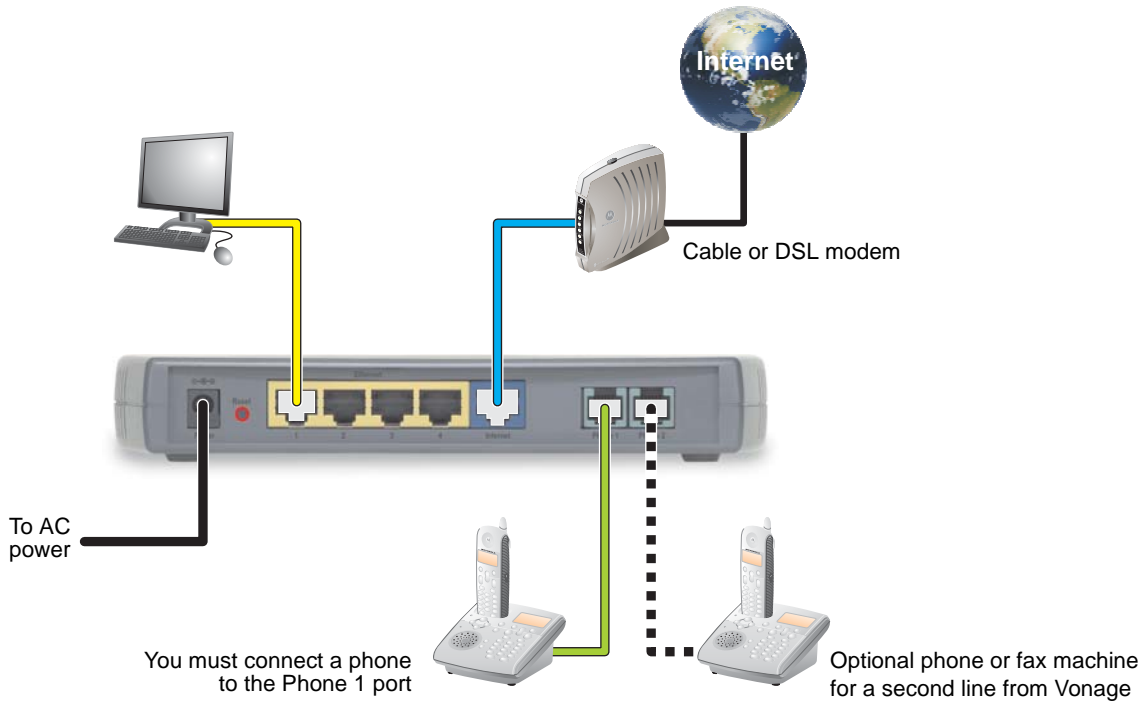

- 1 Shut down your computer properly. Follow the instructions provided with the computer.
- 2 Unplug your cable or DSL modem power cord or adapter.
- 3 Disconnect any cables connecting your computer to the modem. Please leave your modem connected to the cable or phone line that provides your Internet connection.

Hint: Your modem should remain off for about 10 minutes to “clear its memory” so it can recognize the VT2442 when you turn it back on. You can continue with the installation during this time.

- 4 Connect one end of the blue Ethernet cable to the Ethernet port on your modem.
- 5 Connect the other end of the blue Ethernet cable to the blue Ethernet port labeled **Internet** on the rear panel of your voice gateway.
- 6 Connect one end of the yellow Ethernet cable to the **Ethernet 1** port on your voice gateway.
- 7 Connect the other end of the yellow Ethernet cable to the Ethernet port on your computer.

Note: If your high-speed Internet connection was through [USB](#) and your computer does not have an Ethernet adapter, see [“Troubleshooting”](#) on page 65 for information.

Optionally, you can connect up to three more computers directly to the other VT2442 Ethernet ports (2, 3, or 4) using Ethernet cables. You can purchase additional Ethernet cables from any electronics or computer retailer.

- 8 Plug your cable or DSL modem power cord or adapter into an AC power outlet. Refer to the instructions provided with the modem.

IMPORTANT: Before you continue, be sure to allow enough time for your modem to complete its start-up process. Refer to the information provided by the modem manufacturer. For example, startup for a Motorola SURFboard cable modem is complete when its Power, Receive, Send, and Online lights are on and no longer flashing.

- 9 Connect the power adapter supplied with your voice gateway to the **Power** port on its rear panel.

- 10 Plug the other end into an AC power outlet.

This turns on your voice gateway. The VT2442 does not have an On/Off power switch. The Power light on the front panel performs a series of blinks as described in “[Front Panel](#)” on page 3. *You should not unplug your voice gateway when it is not in use.*

IMPORTANT: Before you continue, be sure to allow enough time for your voice gateway to complete its start-up process. VT2442 startup is complete when the Power light on its front panel lights solid green. This usually takes a few minutes.

We recommend plugging the VT2442 power adapter into an electrical outlet that is grounded and equipped with a surge protector or [UPS](#).

- 11 Turn on your computer. The Ethernet 1 light on the VT2442 front panel should light.

IMPORTANT: Before you continue, be sure the VT2442 Power, Ethernet 1, and Internet lights are all on.

- 12 On your computer, open a Web browser such as Microsoft Internet Explorer, Netscape Navigator[®], or Mozilla Firefox[®].

- 13 Check your Internet connection by visiting any website.

If your Internet connection does not work, continue with step 14.

If your Internet connection works, go to [C “Connecting Your Telephone”](#) on page 11.

- 14 Depending on whether your high-speed Internet service is cable or DSL, do *one* of the following:

Cable modem users:

First, as mentioned in step 3, be sure your cable modem remained off for at least 10 minutes before you turned it back on.

If leaving the cable modem unplugged for at least 10 minutes does not correct your problem, you may need to register your VT2442 with your cable provider. Please contact them to update your information. You need to provide them with the **WAN MAC ID** on the bottom of the VT2442.

When your Internet connection works, go to [C “Connecting Your Telephone”](#) on page 11.

DSL modem users:

You may need to configure [PPPoE](#) to work with your VT2442:

- On a computer connected to one of the VT2442 **Ethernet** ports, open a Web browser.
- In the **Address** field, type **http://192.168.15.1** and press **ENTER**.



- In the **Username** and **Password** fields, type **router** and click **Log In**. The HOME page is displayed.
- Click **SETUP** followed by **WAN Configuration**. From the **Type** drop-down list, choose **PPPoE**:

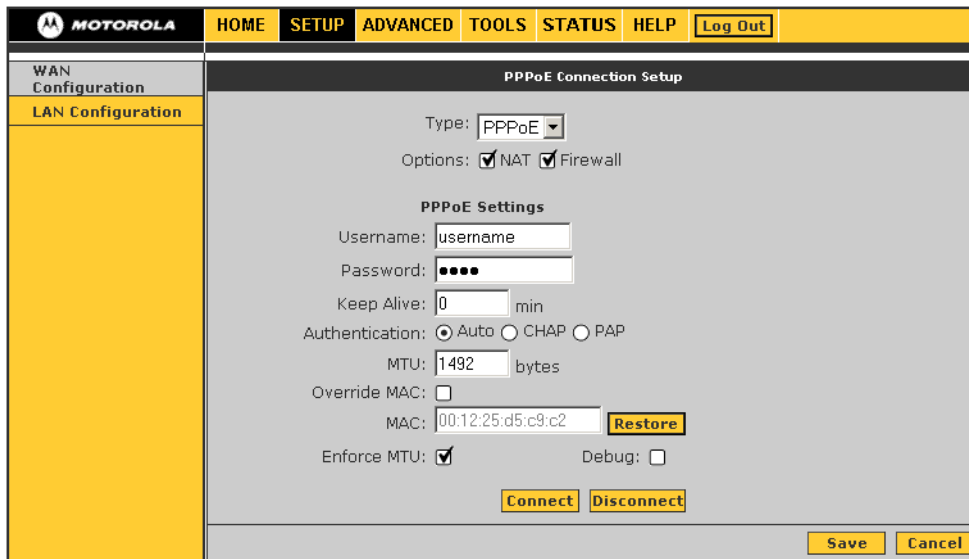

- Type the **Username** and **Password** you normally use to log in to your DSL service.
- In the **Keep Alive** field, type **0** to ensure that your DSL link is always active.
- Click **Connect** to start your Internet connection.
- Click **Save**. Go back to step 13 to test your Internet connection.
- For details and more screen shots, see [“Logging In to the VT2442”](#) on page 13 and [“WAN Setup for PPPoE \(DSL\)”](#) on page 17.

When your Internet connection works, go to [C “Connecting Your Telephone”](#) on page 11.

C Connecting Your Telephone

- 1 Connect a telephone cord to the green **Phone 1** port on the VT2442. If you only subscribed to one phone line from Vonage, you must connect your phone to the Phone 1 port.
- 2 If you subscribed to a second phone or fax line from Vonage, connect a telephone or fax machine to the **Phone 2** port.
- 3 Check for a dial tone. If you hear a recording instructing you to connect your phone to the **Phone 1** port, please do so. If you hear neither this message nor a dial tone, refer to [“Troubleshooting”](#) on page 65.
- 4 If you hear a dial tone, call **1-800-342-1791** to complete your installation.

Basic Configuration

The VT2442 provides a graphical user interface (GUI) to configure Ethernet, router, [DHCP](#), and security settings. It is much easier to configure your local area network (LAN) using a VT2442 than with traditional networking equipment. *For basic operation, most default settings require no modification.*

The following sections describe:

- [Logging In to the VT2442](#) (see page 13)
- [Configuration Overview](#) (see page 14)
- [Restarting the VT2442](#) (see page 15)
- [Logging Out](#) (see page 15)
- [WAN Configuration](#) (see page 16)
- [LAN Configuration](#) (see page 20)

If DHCP is enabled on all of the computers on your home network (LAN), you do not need to change any of the default LAN settings. Unless you have sufficient networking knowledge, we recommend not changing any LAN settings.

For information about advanced configuration, see [“Advanced Configuration”](#) on page 22.

Logging In to the VT2442

- 1 On a computer connected to the VT2442, open a Web browser.
- 2 In the **Address** or **Location** field, type **http://192.168.15.1** and press **ENTER** to display:

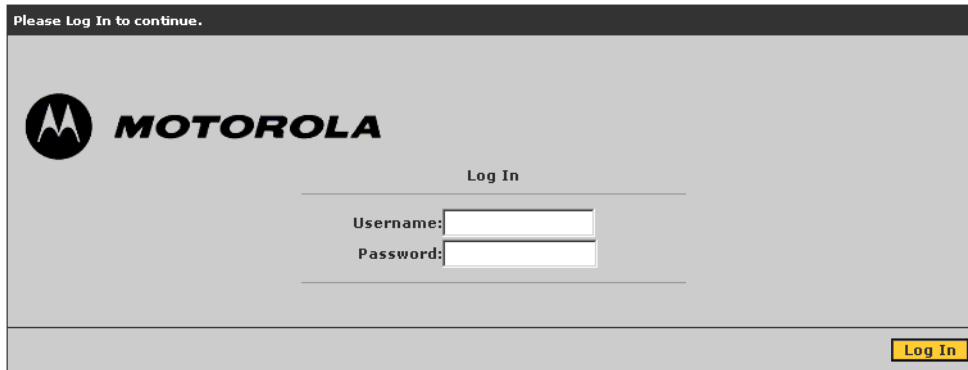

Please Log In to continue.

MOTOROLA

Log In

Username:

Password:

Log In

- 3 In the **Username** field, type **router**.
- 4 In the **Password** field, type the **password** (the default is “router”).
- 5 Click **Log In** to display the HOME page:

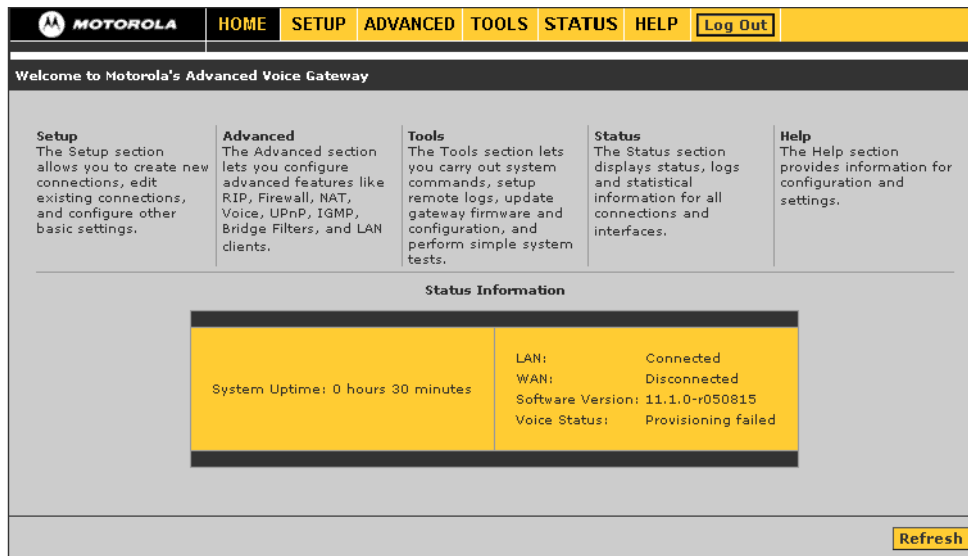

MOTOROLA HOME SETUP ADVANCED TOOLS STATUS HELP Log Out

Welcome to Motorola's Advanced Voice Gateway

Setup
The Setup section allows you to create new connections, edit existing connections, and configure other basic settings.

Advanced
The Advanced section lets you configure advanced features like RIP, Firewall, NAT, Voice, UPnP, IGMP, Bridge Filters, and LAN clients.

Tools
The Tools section lets you carry out system commands, setup remote logs, update gateway firmware and configuration, and perform simple system tests.

Status
The Status section displays status, logs and statistical information for all connections and interfaces.

Help
The Help section provides information for configuration and settings.

Status Information

System Uptime: 0 hours 30 minutes	LAN: Connected
	WAN: Disconnected
	Software Version: 11.1.0-r050815
	Voice Status: Provisioning failed

Refresh

If you have difficulty starting the GUI, see “[Troubleshooting](#)” on page 65.

Configuration Overview

The main menu at the top provides:

Item	Click To
HOME	Display the home page
SETUP	Perform WAN Configuration or LAN Configuration
ADVANCED	Enable/configure UPnP , IP QoS , Web filters, multicast, routing, remote Web access, SSH access, port forwarding, IP filters, and other functionality
TOOLS	Restore, import, export, update, or save the configuration, specify log messages, change the password, determine whether a computer can be reached over the network, or restart the VT2442
STATUS	Display network statistical information
HELP	Display links to information about the Firewall, LAN Clients, PPPoE Connection, UPnP, IP QoS, and RIP
Log Out	Log out of the VT2442

The following buttons appear at the bottom right on each configuration page:

Item	Click To
Save	Save your changes. <i>If you restart your voice gateway without saving your changes, all of your changes are lost. After it restarts, the voice gateway uses its last saved configuration.</i>
Cancel	Clear your changes on the current page and return to the main menu. After you click Save, cancel does not clear your changes.

Exporting the VT2442 Configuration

Before making changes, we recommend exporting the current configuration to use as a “backup.”

To export the VT2442 configuration:

- 1 Click **Tools**.
- 2 Click **Import/Export Configuration** to display the Import/Export Configuration page.
- 3 Click **Export**. The VT2442 configuration is saved a file called config.bin on your computer hard drive.

Importing the Saved Configuration

If you have exported the configuration, you can import the saved configuration to return the voice gateway to its state when you exported the configuration.

To import a saved configuration from your computer to the VT2442:

- 1 Click **Tools**.
- 2 Click **Import/Export Configuration** to display the Import/Export Configuration page.
- 3 Type the path and filename or click **Browse** to select the desired configuration file.
- 4 Click **Import**. The update status appears at the bottom of the window. When the update is finished, the voice gateway restarts. You will need to log in again.

Restarting the VT2442

- 1 Click **TOOLS**.
- 2 Click **Restart** on the menu at left:

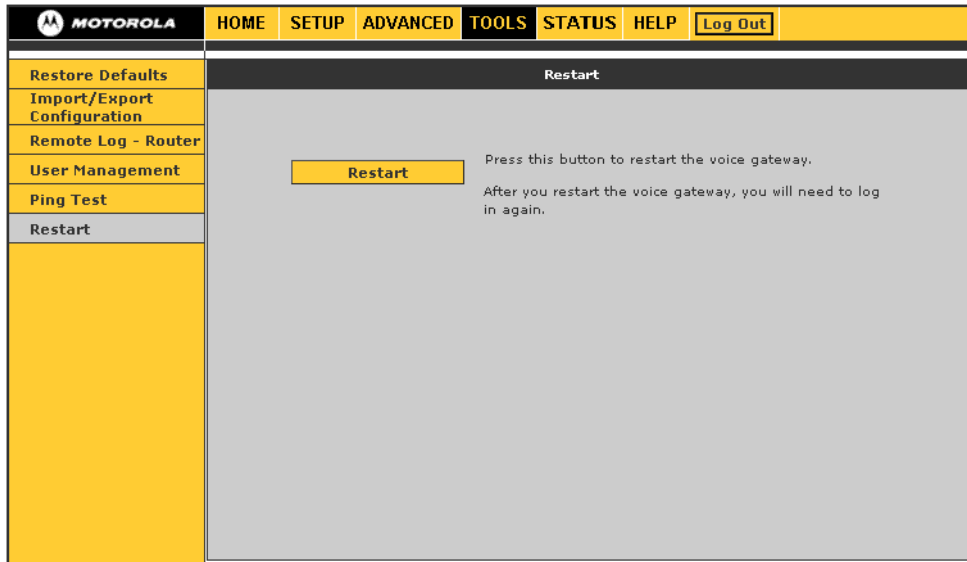

- 3 Click the **Restart** button.

If the VT2442 **Power** light is red after you restart the VT2442, refer to "[Troubleshooting](#)" on page 65.

Logging Out

- 1 On the main menu, click **Log Out**. The text Are you sure you want to Log Out? is displayed.
- 2 Click **Log Out**. The VT2442 login screen appears.

WAN Configuration

- 1 Log in to the VT2442 (see [“Logging In to the VT2442”](#) on page 13).
- 2 Click **SETUP**.
- 3 Click **WAN Configuration**.
- 4 From the **Type** drop-down list, choose *one* of:

PPPoE	PPPoE is used with all DSL modems	See “WAN Setup for PPPoE (DSL)” on page 17
Static	For some cable modems, the cable company assigns the cable modem a static (unchanging) IP address. You must provide the IP address, subnet mask, default gateway, and one to three domain name server (DNS) addresses.	See “WAN Setup for a Static IP Address (Cable Modem)” on page 18
DHCP	Most cable modems have a dynamic IP address assigned by the cable company DHCP server. Typically no additional configuration is needed for the VT2442.	See “WAN Setup for DHCP (Cable Modem)” on page 19

WAN Setup for PPPoE (DSL)

PPPoE Connection Setup fields and buttons

Field or Button	Description
Options	<p>We recommend leaving the following selected:</p> <ul style="list-style-type: none"> NAT — Enables Network Address Translation Firewall — Enables the VT2442 firewall
User name	Your PPPoE user name provided by your DSL provider.
Password	Your PPPoE password provided by your DSL provider.
Keep Alive	Sets the time before your DSL provider terminates an inactive connection. <i>To ensure that your DSL link is always active, type 0 in this field.</i>
Authentication	<p>Sets the authentication:</p> <ul style="list-style-type: none"> Auto — Automatic CHAP — Challenge Handshake Authentication Protocol PAP — Password Authentication Protocol <p>Microsoft CHAP v2 is supported in the Auto and CHAP options. MS CHAP v1 is not supported.</p>
MTU	The maximum transmission unit for the DSL connection. It is a negotiated value that represents the maximum size in bytes of the packets sent over the connection. The default is 1492. The maximum is 1500. The minimum is 64.
Override MAC	If your cable or DSL provider associates a particular service to a specific device, such as your computer, select this field and type that MAC address in the MAC field to use as a “virtual” WAN MAC address instead of the VT2442 MAC address. By default, the MAC address printed on the VT2442 is displayed in this field.
Restore	Restores the actual VT2442 MAC address.
Enforce MTU	If enabled (the default), all TCP segments must have a size within the PPPoE MTU. <i>If you disable this, you may have problems accessing some Internet sites.</i>
Debug	Enables PPPoE debugging for use by technical support personnel <i>only</i> .

PPPoE Connection Setup fields and buttons (continued)

Field or Button Description

Connect	Establishes the DSL connection.
Disconnect	Ends the DSL connection. <i>If you disconnect your DSL connection, your VoIP service cannot work.</i>

WAN Setup for a Static IP Address (Cable Modem)

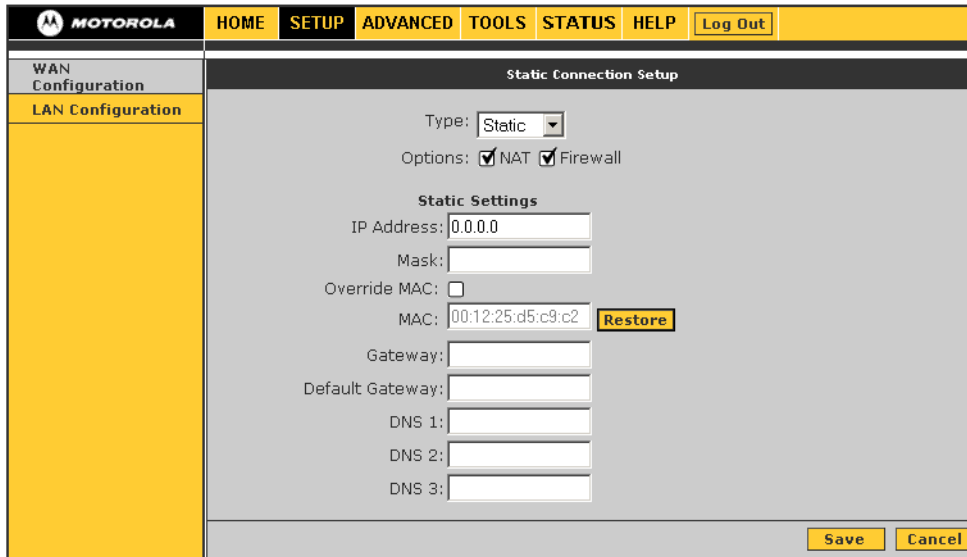

- Options** We recommend leaving the following selected:
- NAT — Enables [Network Address Translation](#)
 - Firewall — Enables the VT2442 firewall

Type the following in dotted-decimal format as assigned by your cable provider:

- | | |
|------------------------|--|
| IP Address | The static IP address |
| Mask | The <i>subnet mask</i> |
| Gateway | The gateway IP address |
| Default Gateway | The default gateway IP address |
| DNS 1, 2, and 3 | One to three domain name server IP addresses |

Optional fields and buttons are:

- | | |
|---------------------|---|
| Override MAC | If your cable or DSL provider associates a particular service to a specific device, such as your computer, select this field and type that MAC address in the MAC field to use as a “virtual” WAN MAC address instead of the VT2442 MAC address. By default, the MAC address printed on the VT2442 is displayed in this field. |
| Restore | Restores the actual VT2442 MAC address. |

WAN Setup for DHCP (Cable Modem)

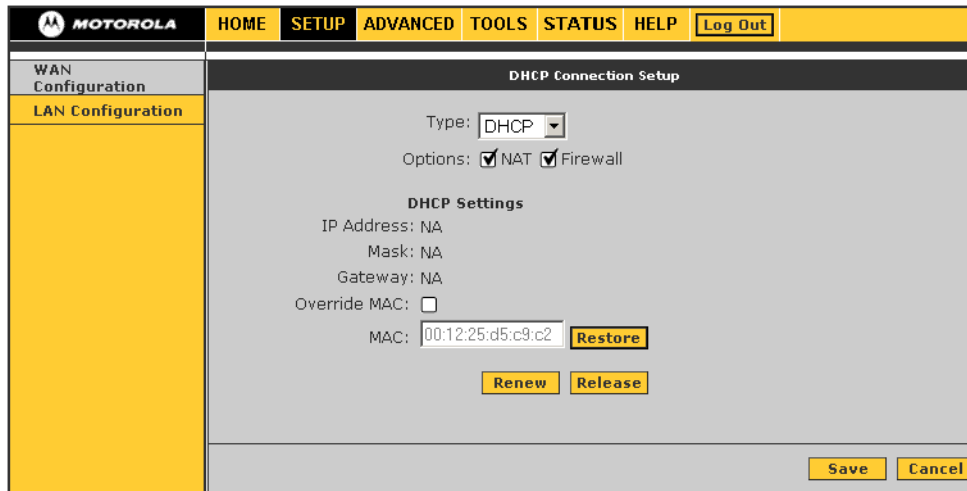

- Options** *We recommend leaving the following selected:*
- NAT — Enables [Network Address Translation](#)
 - Firewall — Enables the VT2442 firewall

Optional fields and buttons are:

- Override MAC** If your cable or DSL provider associates a particular service to a specific device, such as your computer, select this field and type that MAC address in the **MAC** field to use as a “virtual” [WAN MAC address](#) instead of the VT2442 MAC address. By default, the MAC address printed on the VT2442 is displayed in this field.
- Restore** Restores the actual VT2442 MAC address.
- Renew** Requests a new WAN IP address for your VT2442 from the [DHCP](#) server at Vonage.
- Release** Releases the VT2442 WAN IP address.

LAN Configuration

If DHCP is enabled on all of the computers on your home network (LAN), you should not need to change any of the default LAN settings. For information about enabling DHCP, see “Configuring TCP/IP” on page 53.

Unless you have sufficient networking knowledge, we recommend not changing any LAN settings.

LAN Configuration fields and buttons

Field or Button	Description
-----------------	-------------

Subnet IP Address	Sets your LAN subnetwork IP address in dotted-decimal format . <i>We recommend not changing the default 192.168.15.0.</i>
Netmask	Sets the VT2442 subnet mask , in dotted-decimal format. The default is 255.255.255.0, which enables the VT2442 router to support up to 253 users connected through multiple hubs, switches, routers, or wireless access points.
Default Gateway	Sets the default gateway IP address for your network, in dotted-decimal format. It must be in the range for the subnet specified by Subnet IP Address and Netmask. <i>We recommend not changing the default 192.168.15.1.</i>
Host Name	Sets the voice gateway host name. It can contain any alphanumeric characters, except spaces.
Domain	Sets the domain name. It is used in conjunction with the host name to uniquely identify the voice gateway. To access the web pages of the voice gateway you can type 192.168.15.1 (the IP address) or mygateway1.rgw (hostname.domain).

LAN Configuration fields and buttons (continued)

Field or Button	Description
-----------------	-------------

Enable DHCP Server	<p>If selected, the DHCP server on the voice gateway assigns IP addresses to the computers and other hosts on your network, if they have DHCP enabled (see “Configuring TCP/IP” on page 53). By default, the voice gateway DHCP server is enabled.</p> <p><i>If there is another DHCP server running on your network (on another router), you must disable one of the DHCP servers.</i></p>
Start IP	<p>Sets the first IP address assigned by the DHCP server, in dotted-decimal format. It must be greater than the IP address value of the voice gateway. For example, if the IP address of the voice gateway is 192.168.15.1 (default), the starting IP address must be 192.168.15.2 (or higher).</p>
End IP	<p>Sets the final IP address assigned by the DHCP server, in dotted-decimal format. It cannot exceed the subnet limit of 254. For example, the default is 192.168.15.254. If the DHCP server runs out of DHCP addresses, users cannot access network resources. If this happens, increase the End IP (to the limit of 254) or reduce the Lease Time.</p> <p>If you change Start IP or End IP, be sure they are in the range for specified by the Subnet IP Address and Netmask. For example, if the voice gateway IP address is 192.168.15.1 (the default) and you set Start IP and End IP to 192.168.0.2 and 192.168.0.100, respectively, computers with DHCP enabled cannot communicate with the voice gateway.</p>
Lease Time	<p>Sets the time, in seconds, that a network computer remains connected to the voice gateway using its current assigned IP address. At the end of this time, the DHCP server renews the lease or assigns the computer a new IP address. The default is 3600 seconds (1 hour). The maximum is 999999 seconds (about 278 hours).</p>
Enable DHCP Relay	<p>If selected, the voice gateway forwards requests and responses between the computers on your network (the DHCP clients) and the DHCP server you chose to use for your network.</p>
Relay IP	<p>If you select Enable DHCP Relay, type the IP address of the DHCP server in dotted-decimal format.</p>
Server and Relay Off	<p>If selected, you must carefully configure the IP address, Subnet Mask, and DNS settings of every host on your network. Do not assign the same IP address to more than one host. Your voice gateway must be on the same subnet as the other hosts.</p>

Advanced Configuration

This section describes the [ADVANCED](#), [TOOLS](#), and [STATUS](#) menus.

ADVANCED

The ADVANCED menu provides the following links:

- [UPnP](#) — enable Universal Plug and Play
- [IP QoS](#) — assign priority to Internet traffic
- [Port Forwarding](#) — direct incoming traffic to specific computers on your network
- [IP Filters](#) — block applications and services based on the IP address of a LAN device
- [LAN Clients](#) — determine how computers on your network receive an IP address
- [Web Filters](#) — specify whether proxies, cookies, Java applets, ActiveX controls, or pop-ups can pass through your voice gateway
- [Dynamic DNS Client](#) — register your voice gateway with a DNS server to access the voice gateway each time from the WAN using the host name
- [Multicast](#) — enable IGMP Multicast
- [Static Routing](#) — define up to 16 static routes in the voice gateway routing table
- [Dynamic Routing](#) — define dynamic routes using routing information protocol (RIP)
- [Remote Web Access](#) — enable access to the voice gateway remotely over the Web
- [Remote SSH Access](#) — access the voice gateway remotely via secure shell
- [Ethernet Switch](#) — configure Ethernet switch settings

UPnP

Universal Plug and Play (UPnP) requires one active WAN connection and the host should support this feature.

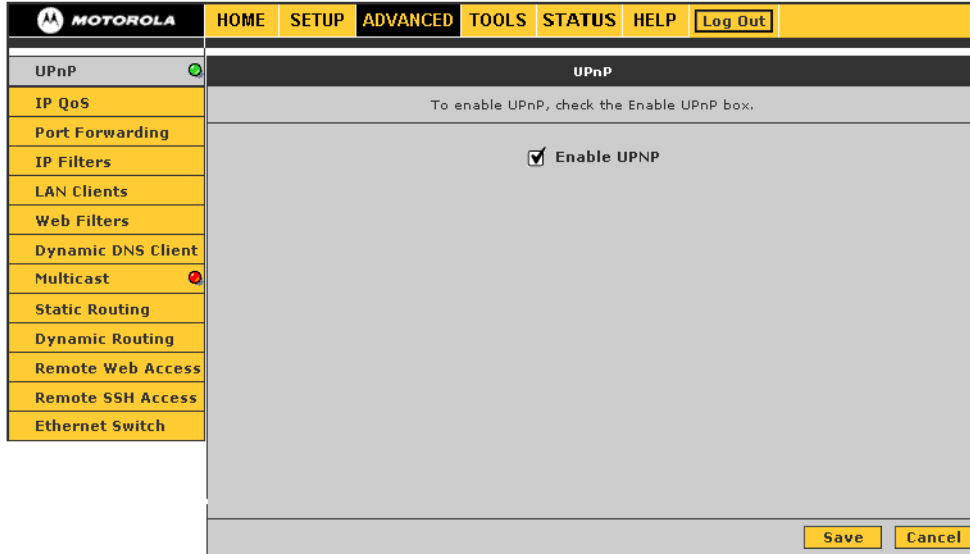

UPnP fields

Field	Description
-------	-------------

Enable UPnP	Enables UPnP so traffic for applications using UPnP can pass through the voice gateway.
--------------------	---

IP QoS

IP quality of service (QoS) enables you to assign priority to Internet traffic based on the source and destination IP addresses, source and destination ports, packet length, and protocol.

The screenshot shows the IP QoS configuration page. At the top, there are navigation tabs: HOME, SETUP, ADVANCED, TOOLS, STATUS, HELP, and Log Out. The left sidebar contains a menu with items: UPnP, IP QoS, Port Forwarding, IP Filters, LAN Clients, Web Filters, Dynamic DNS Client, Multicast, Static Routing, Dynamic Routing, Remote Web Access, Remote SSH Access, and Ethernet Switch. The main content area is titled 'IP QoS' and contains two checked checkboxes: 'Enable IPQoS' and 'Trusted Mode'. Below these is a table with columns: Name, Source IP, Source Port, Destination IP, Destination Port, Pkt Len, Protocol, Priority, Phy Port, TOS, and Delete. An 'Add' button is located at the bottom right of the table area. A callout box points to the table with the text 'This table displays all defined rules'.

IP QoS fields and buttons

Field or Button	Description
Enable IPQoS	If selected, traffic prioritization is enabled (the default).
Trusted Mode	If enabled (the default), all IP QoS traffic rules are applied first, regardless of the TOS bit settings. After the rules are exhausted, the existing TOS bit settings are honored. If disabled, all rules are also applied, except if there is no match, a default rule of queuing priority Low is used.
Add	Displays the IP QoS Traffic Rule window, where you can define rules.

IP QoS Traffic Rule

This window displays when you click **Add** on the [IP QoS](#) window. It enables you to define rules for filtering packets.

IP QoS Traffic Rule fields

Field	Description
Rule Name	The rule name
Source IP	Sets the source IP address for the rule.
Source Start Port	Sets the source start port.
Destination IP	Sets the destination IP address.
Destination Start Port	Sets the destination start port.
Packet Length Start	Sets the minimum packet size for the rule.
Protocol	Sets the protocol — TCP, UDP, ICMP, or Any.
Traffic Priority	Sets the priority for traffic matching these characteristics — High or Low.
Source Netmask	Sets the source subnet mask, which along with the Source IP specifies a range of source IP addresses.
Source End Port	Sets the source end port.
Destination Netmask	Sets the destination subnet mask, which along with the Destination IP specifies a range of destination IP addresses.
Destination End Port	Sets the destination end port.
Packet Length End	Sets the maximum packet size allowed by the rule.
Physical Port	Can be none, Port 1, Port 2, Port 3, Port 4, or WLAN.

IP QoS Traffic Rule fields (continued)

Field	Description
Normal Service	Packets matching the rule are treated as normal packets requiring no special treatment along the path. Normal packets have TOS byte 0 in the IP Header.
TOS Marking	Enables you to assign a TOS value to this traffic — No Change, Normal Service, Minimize monetary cost, Maximize reliability, Maximize throughput, or Minimize delay. The priority bits in the TOS byte are set to zero upon marking and derived based on priority queues. The priority bit value for each priority queue is: <ul style="list-style-type: none">• Voice (EF1): 5• High (EF2): 4• Medium: 3• Low: 1

Port Forwarding

Port forwarding enables you to direct incoming traffic to specific LAN hosts (computers on your network) based on the protocol and port number. It is used to play Internet games or provide local services (such as web hosting) for a LAN group. Port forwarding is also referred to as “virtual servers.” You can:

- Apply predefined port forwarding rules to one or more computers
- If you have the necessary networking knowledge, create, edit, or delete your own port forwarding rules
- Add a computer to the [DMZ](#)

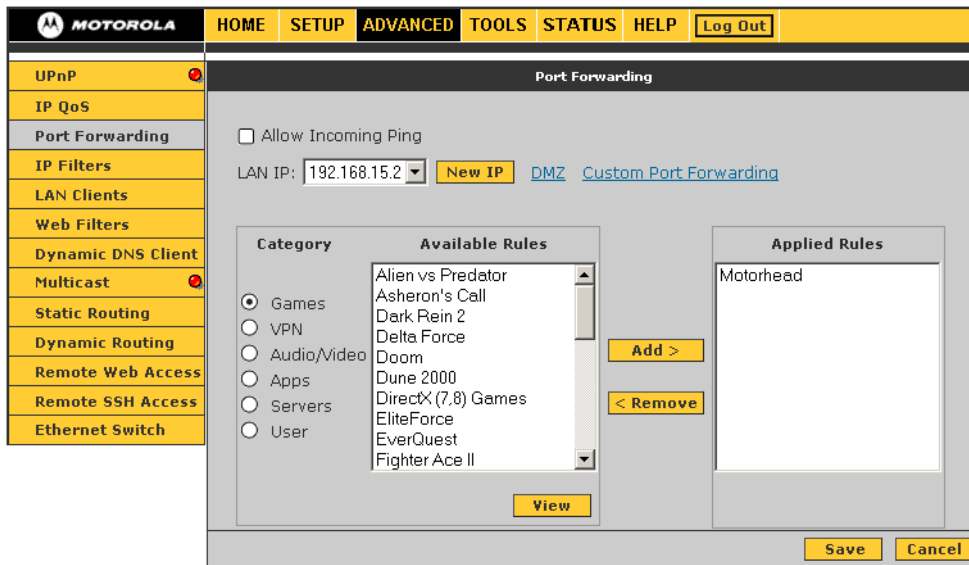

Port Forwarding fields and buttons

Field or Button	Description
Allow Incoming Ping	Enables the voice gateway to respond to a ping from the Internet.
LAN IP	Select the IP address to host the service.
New IP	Displays the LAN Clients window to reserve an IP address.
DMZ	Displays the DMZ Settings page.
Custom Port Forwarding	Displays the Custom Port Forwarding page.
Category	Sets the category for which rules are displayed in the Available Rules list — Games, VPN, Audio/Video, Apps (applications), Servers, or User (custom rules you can define and edit).
Available Rules	Lists the available rules in the selected Category.

Port Forwarding fields and buttons (continued)

Field or Button

Description

View

Displays the protocols and port ranges for the selected Available Rule. For example, if you select Alien vs. Predator and click **View**, the following is displayed:

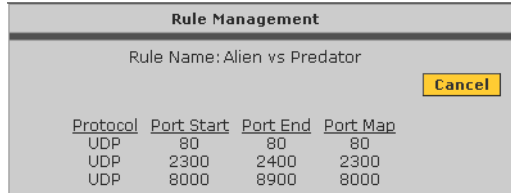

Rule Management			
Rule Name: Alien vs Predator			
Cancel			
Protocol	Port Start	Port End	Port Map
UDP	80	80	80
UDP	2300	2400	2300
UDP	8000	8900	8000

Click **Cancel** to return to the Port Forwarding page.

Add

Adds the selected Available Rule to the Applied Rules list.

Remove

Remove the selected rule from the Applied Rules list.

Applied Rules

Lists the IP filtering rules you selected to apply for each given category.

Custom Port Forwarding

You can create up to 20 custom port forwarding entries to support specific services or applications, such as concurrent NAT/NAPT operation.

Custom Port Forwarding fields

Field	Description
Enable	The check box is selected by default and automatically applies when you click Apply .
Application	The name of the application for which ports are opened.
Protocol	Can be TCP, UDP and TCP, or UDP.
Source IP Address	Sets the source IP address from which incoming traffic is allowed.
Source Netmask	Sets a subnet mask used in conjunction with the Source IP Address to set a range of IP addresses. Enter 0.0.0.0 for all.
Destination IP Address	The LAN's destination IP address for incoming traffic.
Destination Netmask	Subnet mask used in conjunction with the Destination IP Address to set a range of IP addresses. The default is 255.255.255.255.
Destination Port Start	The starting port number that is opened for this application.
Destination Port End	The ending port number that is opened for this application.
Destination Port Map	Destination port mapped on the LAN (destination) side to which packets are forwarded. There are two types of port mapping: <ul style="list-style-type: none"> • One-to-one (one port mapped to one) (WAN = 500 to 600; LAN = 500 to 600) • Multiple-to-one (several ports mapped to one) (WAN = 500 to 600; LAN = 700) Wildcard (*) entries are allowed for the IP Address, Netmask, and Port range fields.

DMZ Settings

Configuring a computer as a demilitarized zone (DMZ) forwards any network traffic that is not redirected to another computer through port forwarding to the IP address of the computer. This allows access to the DMZ host from the Internet.

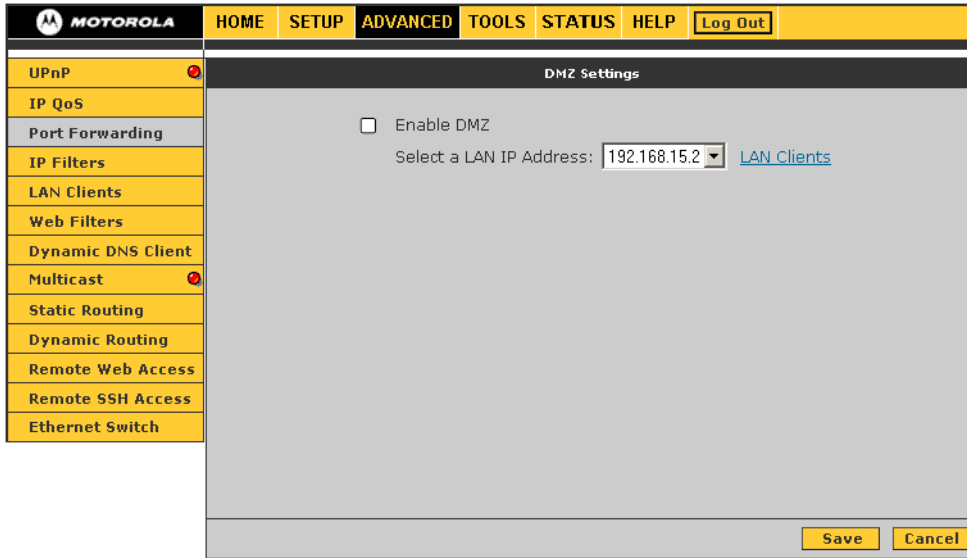

DMZ Settings fields

Field	Description
Enable DMZ	Enables or disables the DMZ feature. It is disabled by default.
Select a LAN IP Address	Selects the LAN IP address of the DMZ computer to expose to the Internet with no protection from the VT2442 firewall. <i>This may expose your network to security risks.</i>
LAN Clients	Displays the LAN Clients page to configure the DMZ computer.

IP Filters

IP filtering enables you to block applications and services based on the IP address of a LAN device. You can apply one or more predefined IP filtering rules to one or more LAN computers. You can view the rules associated with a predefined filter and add the available rules for a given category. You can also create, edit, or delete your own IP filter rules.

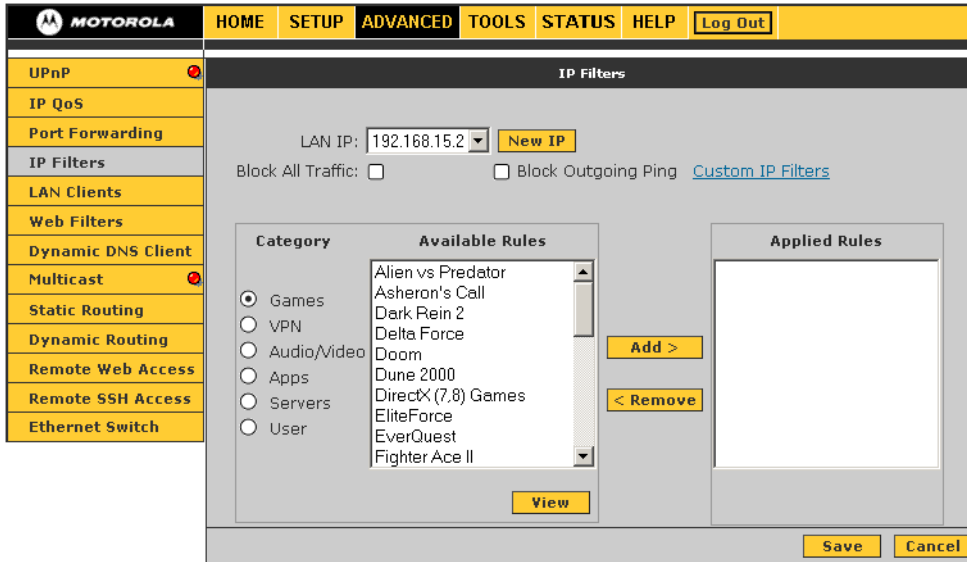

IP Filters fields and buttons

Field or Button	Description
LAN IP	The IP address in the LAN group to which the IP filters are applied.
New IP	Displays the LAN Clients page.
Block All Traffic	If selected, network access is blocked for the IP address.
Block Outgoing Ping	If selected, outgoing pings are blocked for the IP address. Blocking outgoing pings can be useful if a computer has a virus that attempts a Ping-of-Death denial of service attack.
Custom IP Filters	Displays the Custom IP Filters page
Category	Sets the category for which rules are displayed in the Available Rules list — Games, VPN, Audio/Video, Apps (applications), Servers, or User (custom rules you can define and edit).
Available Rules	Predefined and user-defined IP filtering rules for each category.
View	Displays the settings for the selected Available Rule.
Add	Adds the selected Available Rule to the Applied Rules list.
Remove	Removes the selected rule from the Applied Rules list.
Applied Rules	Lists the IP filtering rules selected for the category.

Custom IP Filters

You can define up to 20 custom filters to block services or applications based on the source and destination IP address, subnet mask, TCP port, and protocol.

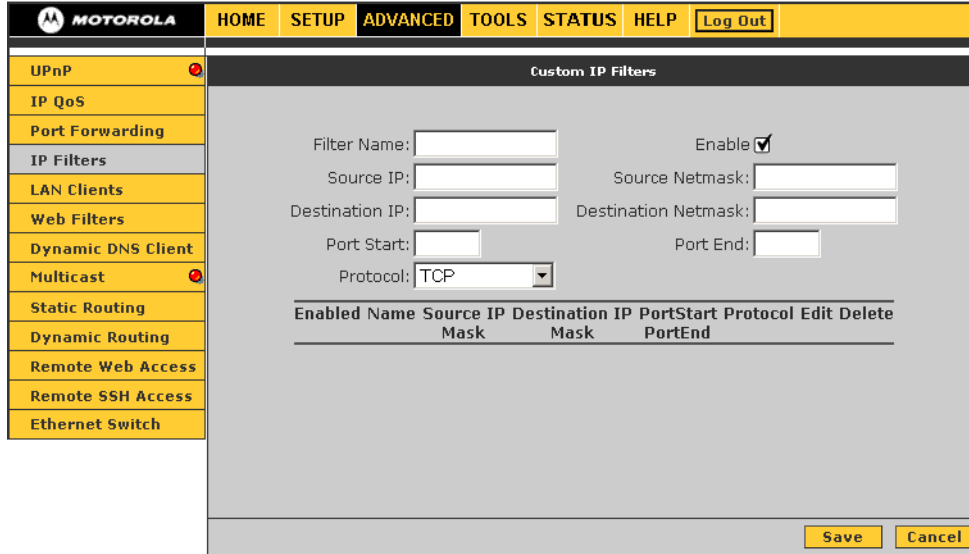

Custom IP Filters fields

Field

Description

Filter Name	The IP filter rule name.
Enable	Selected by default and automatically applied when you click Save .
Source IP	The LAN source IP address assigned to outgoing traffic on which filtering is applied
Source Netmask	Subnet Mask of the source IP address.
Destination IP	Sets the destination IP address to which your source IP address is denied access.
Destination Netmask	Subnet mask of the destination IP address. Enter 0.0.0.0 for all.
Port Start	The starting port number that will be blocked for this application.
Port End	The ending port number that will be blocked for this application.
Protocol	The options are TCP, UDP, TCP and UDP, ICMP, or Any.

LAN Clients

The LAN Clients window displays all computers on your network. For each computer on your LAN, you can do one of:

- Allow it to dynamically (automatically) obtain its IP address from the voice gateway through a DHCP lease from the DHCP server on the VT2442 (the default)
- Allow it to dynamically obtain its IP address from a DHCP server on another router on the network
- Manually assign it a static IP address in the voice gateway LAN subnet address range

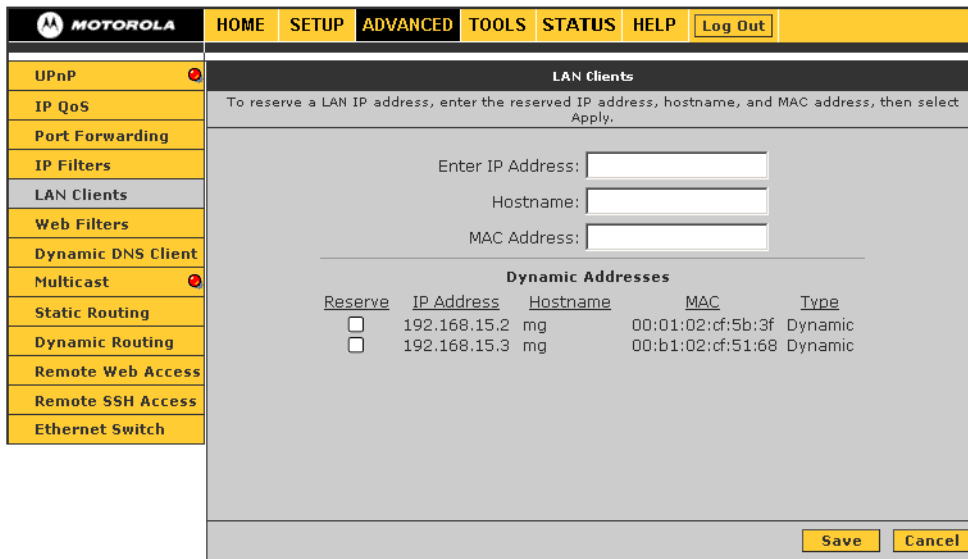

LAN Clients fields

Field	Description
Enter IP Address	Type the static IP address to assign to the computer or other host. For that host, type its Hostname (optional) and MAC address (required)
Dynamic Addresses	Lists the currently assigned dynamic IP addresses and the hostname, MAC address, and address Type (always Dynamic in this table) of the assigned computer. To assign a dynamic IP address to the computer as a static IP address, select the Reserve check box.
Static Addresses	(Not shown above.) If any static IP addresses are reserved, lists them and the host name, MAC address, and address Type (always Static in this table) of the assigned computer. To remove a static IP address assignment from a computer, select the Delete check box. If you delete a static IP address entry, it is made available for future allocation.

Web Filters

Web Filters enable you to manage the type of web content that passes through your voice gateway:

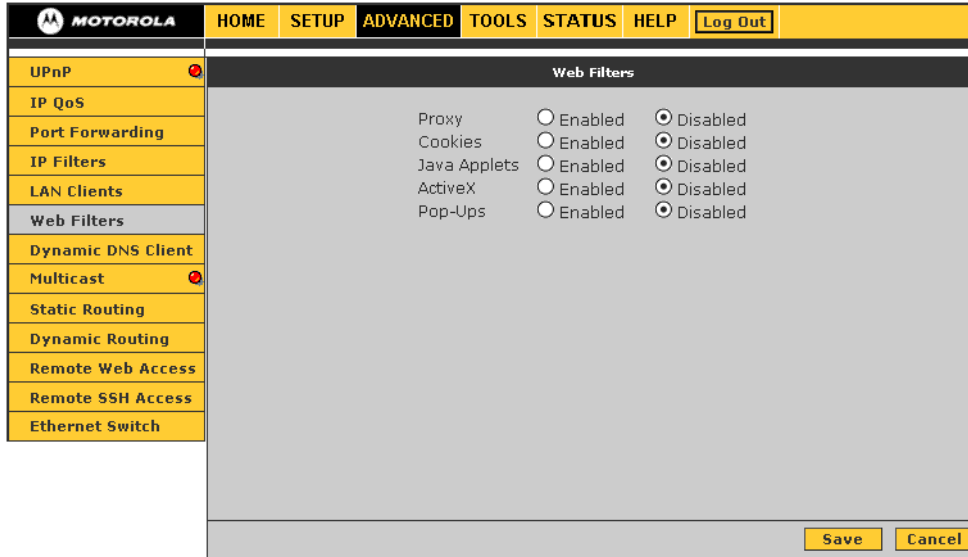

Web Filters fields

Field	Description
Proxy	Disabled by default.
Cookies	Disabled by default.
Java Applets	Disabled by default.
ActiveX	Disabled by default.
Pop-Ups	Disabled by default.

Dynamic DNS Client

You can register your voice gateway with a DNS server to access the voice gateway from the Internet using its host name.

Dynamic DNS Client fields

Field	Description
DDNS Server	Selects a DDNS service provider from the list. A charge may occur, depending on the service selected.
DDNS Client	Enables or disables the DDNS client feature for the WAN connection. It is disabled by default.
User Name	The user name assigned by the DDNS service provider.
Password	The password assigned by the DDNS service provider.
Domain Name	The dynamic domain name to be registered with the DDNS server.

Multicast

Multicasting is a form of limited broadcast. UDP is used to send datagrams to all computers in a host group, one or more hosts identified by the same destination IP address. The following statements apply to host groups:

- Anyone can join or leave a host group.
- There are no restrictions on the host location.
- There are no restrictions on the number of members that may belong to a host group.
- A host may belong to multiple host groups.
- Non-members can send UDP datagrams to the host group.

Multicasting is useful when the same data needs to be sent to more than one device; for example, if one device is responsible for acquiring data that many other devices need. Using multicasting uses less network bandwidth than sending the same data to individual devices.

Multicasting also enables you to receive multicast video streams from multicast servers. The voice gateway supports an Internet Group Management Protocol (IGMP) proxy that handles IGMP messages. When enabled, the voice gateway acts as a proxy for a LAN host making requests to join and leave multicast groups.

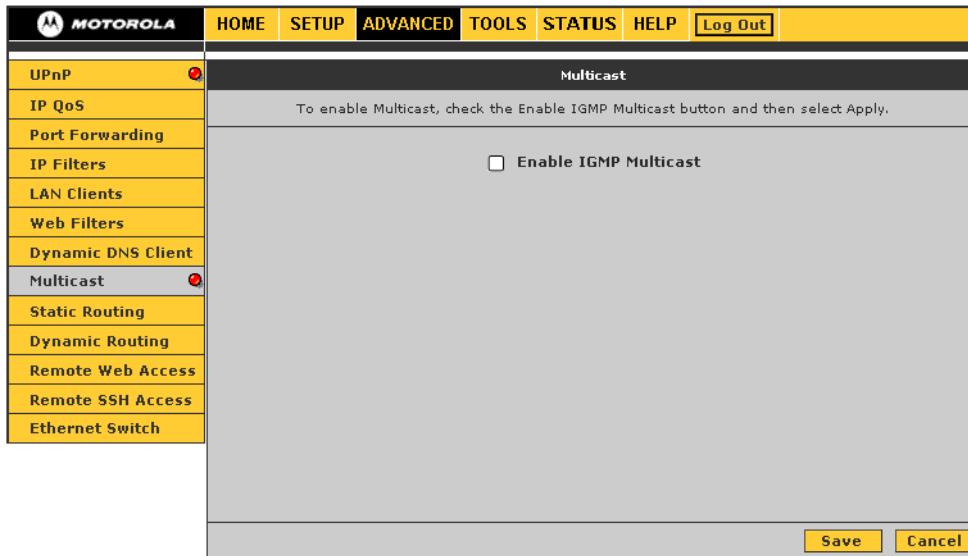

Multicast fields

Field	Description
Enable IGMP Multicast	Enables an IGMP proxy for multicast messages. The voice gateway acts as a proxy for a LAN computer requesting to join or leave multicast groups.

Static Routing

You can define up to 16 static routes in the voice gateway routing table for specific WAN and LAN subnets.

Static Routing fields

Field	Description
New Destination IP	The network IP address of the subnet. (You can also enter the IP address of each individual station in the subnet).
Mask	The network mask of the destination subnet.
Gateway	The IP address of the next hop through which traffic will flow towards the destination subnet.
Metric	Defines the number of hops between the network nodes through which data packets travel. The default is 0, which means the subnet is directly one hop away on the LAN.

Dynamic Routing

Dynamic routing enables you to define dynamic routes using Routing Information Protocol (RIP) to exchange routing information with other network routers across the WAN (Internet) and LAN interfaces.

The screenshot shows the 'Dynamic Routing' configuration page. At the top, there is a navigation bar with 'HOME', 'SETUP', 'ADVANCED', 'TOOLS', 'STATUS', 'HELP', and 'Log Out'. A sidebar on the left lists various configuration options, with 'Dynamic Routing' selected. The main content area contains the following fields:

- Enable RIP
- Protocol:
- Enable Password
- Password:
- Interface: LAN, WAN
- Direction: Both, None

At the bottom right, there are 'Save' and 'Cancel' buttons.

Dynamic Routing fields

Field	Description
Enable RIP	Enables RIP. Any RIP-enabled router: <ul style="list-style-type: none"> Sends automatic update packets containing its routing table periodically (every 30 seconds) Adds, deletes, or modifies routes in its routing table based on periodic updates from other routers Responds to requests for its routing table
Protocol	Sets the RIP version: <ul style="list-style-type: none"> RIP v1 (UDP protocol) RIP v2 (multicast protocol) RIP v1 compatible (UDP protocol with multicast format) Routers using RIP v1 or a compatible protocol can communicate with each other, but not to routers using RIP v2.
Enable Password	(Optional) RIP v2 enables simple plain-text password-based authentication for RIP packets. It is disabled if RIP v1 is selected.
Password	The password can have up to 16 characters.
Interface	Normally, when it is enabled on a router, RIP dynamically provides routes on all configured interfaces. On the VT2442, you can select which routes are distributed through the network: <ul style="list-style-type: none"> LAN — Sets the direction in which RIP messages are sent on the LAN interface WAN — Sets the direction in which RIP messages are sent on the WAN interface The options for LAN and WAN are: <ul style="list-style-type: none"> Both — receive and send updates to the routing table to other routers on the interface In — receive but do not send routing updates on that interface Out — send but do not receive routing updates on the interface None — do not send or receive routing updates through the interface

Remote Web Access

Web access control enables you to access the voice gateway remotely over the Web.

Field	Value
Enable	<input type="checkbox"/>
Remote Network IP	0.0.0.0
Remote Netmask	255.255.255.255
Redirect Port	8080

Remote Web Access fields

Field	Description
Enable	Enables and disables the remote web access feature.
Remote Network IP	Enter the IP address of the remote host (for example, 10.10.10.1).
Remote Netmask	Enter the subnet mask of the remote host.
Redirect Port	You can enter a port in this field that is different from port 8080. The port you enter is viewed externally and mapped to port 8080 internally on the voice gateway.

Remote SSH Access

You can access the voice gateway remotely through secure shell (SSH) over the Internet.

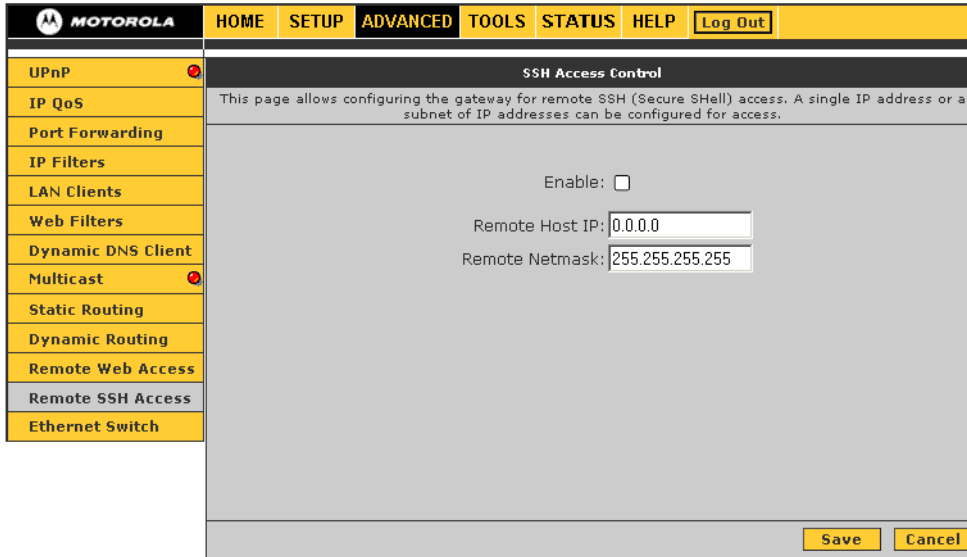

Remote SSH Access fields

Field	Description
Enable	Enables or disables remote SSH access.
Remote Host IP	Sets the IP address of the remote SSH host.
Remote Netmask	Sets the subnet mask of the remote SSH host.

Ethernet Switch

If automatic detection does not work for some reason, you can configure Ethernet switch settings to meet your requirements.

	Set Value	Fallback Value
Physical Port1:	Auto	Disabled
Physical Port2:	Auto	Disabled
Physical Port3:	Auto	Disabled
Physical Port4:	Auto	100/Full Duplex

Ethernet Switch fields

Field	Description
Physical Ports 1 to 4	Sets the speed for Ethernet ports 1 to 4. It can be Auto detect (the default), 10 Mbps half duplex, 10 Mbps full duplex, 100 Mbps half duplex, or 100 Mbps full duplex.

TOOLS

The TOOLS menu provides the following links:

- [Restore Defaults](#) — restore the default configuration to the voice gateway
- [Import/Export Configuration](#) — import or export the voice gateway configuration
- [Remote Log – Router](#) — specify the log messages the voice gateway sends to remote computers
- [User Management](#) — change the voice gateway password
- [Ping Test](#) — determine whether a computer can be reached over the network
- [Restart](#) — save the configuration or restart the VT2442

Restore Defaults

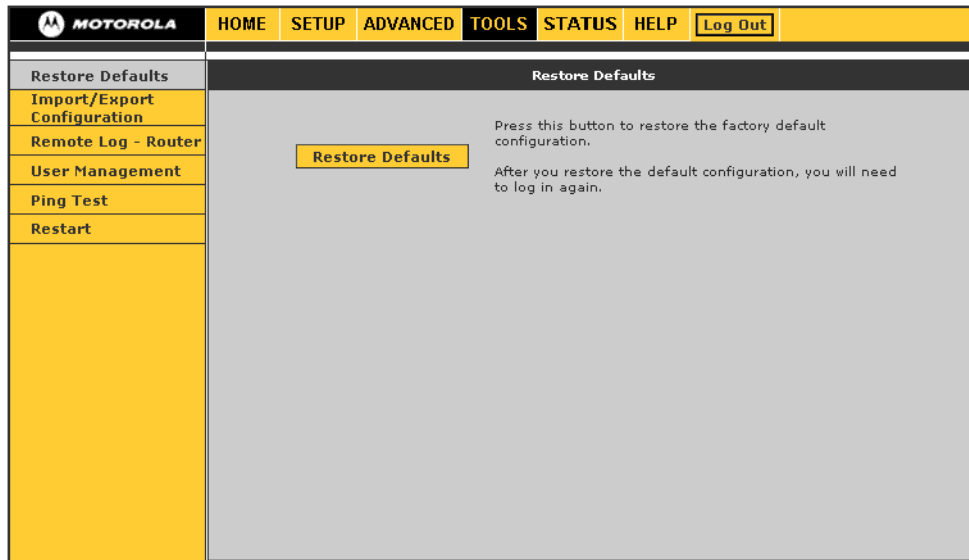

Button	Description
Restore Defaults	Restores the factory default configuration. After you restore the defaults, you must log in again to the voice gateway.

Import/Export Configuration

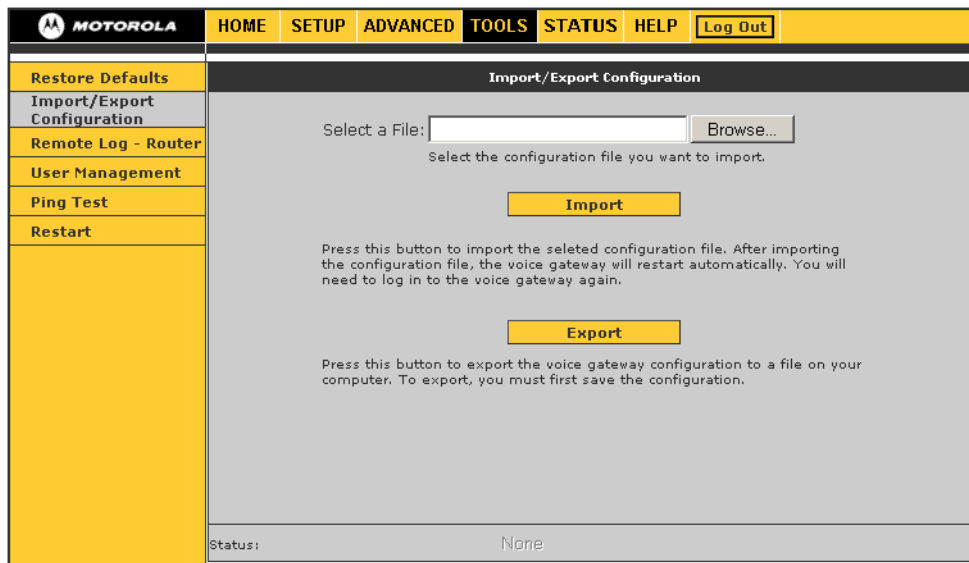

Import/Export Configuration fields and buttons

Field or Button	Description
Select a File	Click Browse to select the configuration file to import to the voice gateway.
Import	Imports the selected configuration file. The update status appears at the bottom of the window. When the update is finished, the voice gateway restarts and you will need to log in again.
Export	Downloads a copy of the configuration file (config.bin) saved in the voice gateway flash memory to your hard drive.

Remote Log – Router

You can forward logged events of a specified severity level or higher to a remote computer. Each log message is assigned a severity level, which indicates how seriously the triggering event affects voice gateway functions.

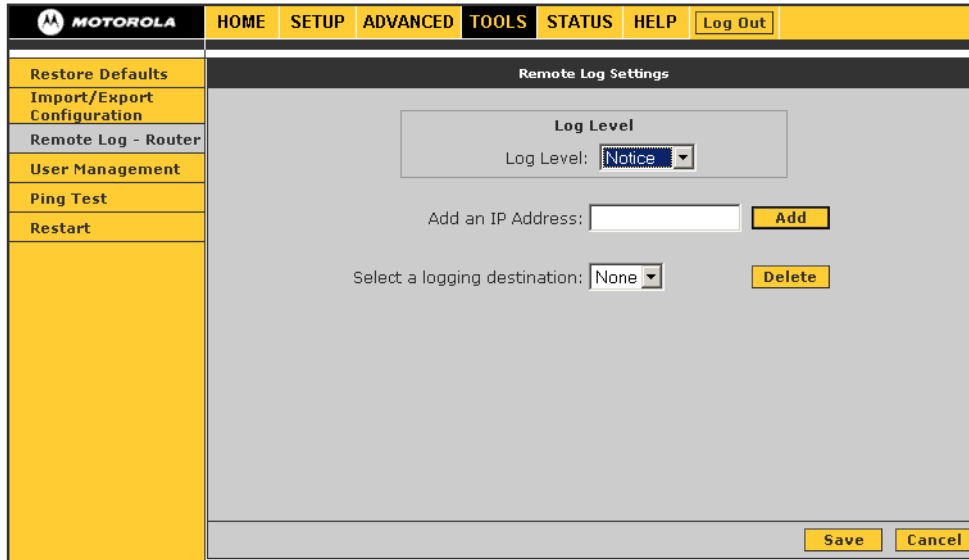

Remote Log – Router fields

Field	Description
Log Level	<p>Messages having the severity level you specify, or higher, are logged to the logging destination you select. The levels are, in order of severity:</p> <ul style="list-style-type: none"> • Panic — system panic or other condition that causes the voice gateway to stop functioning • Alert — conditions that require immediate correction, such as a corrupted system database • Critical — critical conditions, such as hard drive errors • Error — error conditions that generally have less serious consequences than panic, alert, or critical errors • Warning — conditions that warrant monitoring • Notice — conditions that are not errors but might warrant special handling; this is the default Log Level setting • Info — events or non-error conditions of interest • Debug — software debugging messages; <i>specify this level only when directed by a technical support representative</i>
Add an IP Address	<p>Type the IP address of the remote host where you want log information sent and click Add. You can add multiple IP addresses using the Add button. Any IP address you add here appears in the Select a logging destination drop-down list.</p>
Select a logging destination	<p>From the list, select the IP address to which you want the log information sent.</p>

User Management

Use this window to change the password for the User Name router.

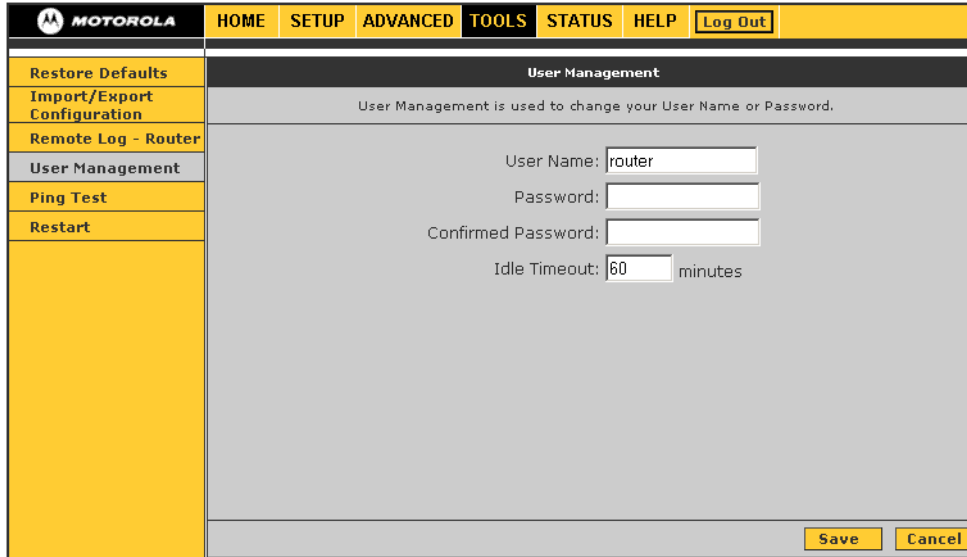

The screenshot shows the Motorola web interface for User Management. The top navigation bar includes HOME, SETUP, ADVANCED, TOOLS, STATUS, HELP, and Log Out. The left sidebar contains links for Restore Defaults, Import/Export Configuration, Remote Log - Router, User Management (selected), Ping Test, and Restart. The main content area is titled "User Management" and contains the following text: "User Management is used to change your User Name or Password." Below this text are four input fields: "User Name:" with the value "router", "Password:", "Confirmed Password:", and "Idle Timeout:" with the value "60" and the unit "minutes". At the bottom right of the form are "Save" and "Cancel" buttons.

Ping Test

Use this page to determine whether you can access an IP address from your computer.

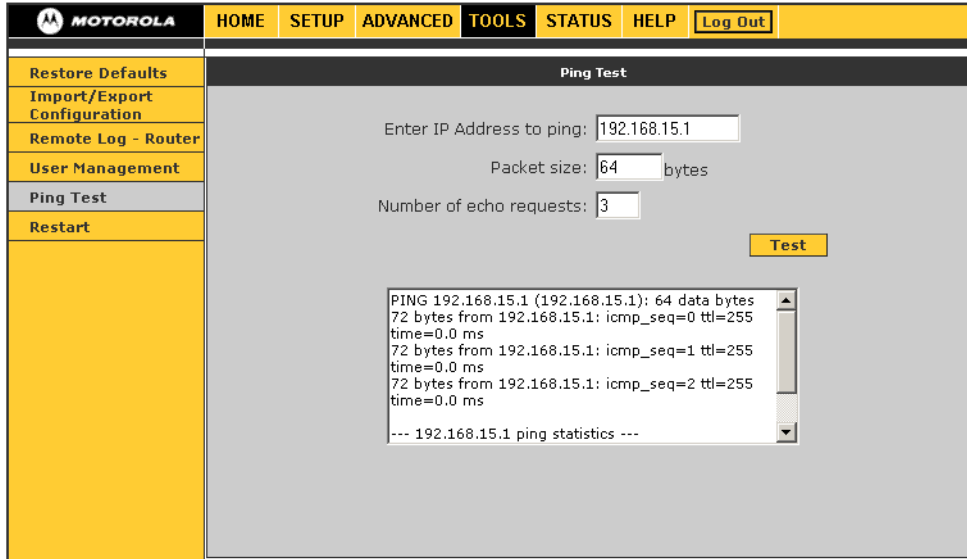

Ping Test fields and buttons

Field or Button	Description
Enter IP Address to ping	Sets the IP address to ping; the default is the VT2442 default IP address 192.168.15.1.
Packet size	Sets the packet size of the ping test. The default is 64 bytes.
Number of echo requests	Sets how many times the IP address is pinged. The default is 3.
Test	Starts the test. The results display in the scroll window: <ul style="list-style-type: none"> • If the test is successful, you can access the IP address. • If the test is unsuccessful, you should restart the VT2442 (see “Restarting the VT2442” on page 15).

Restart

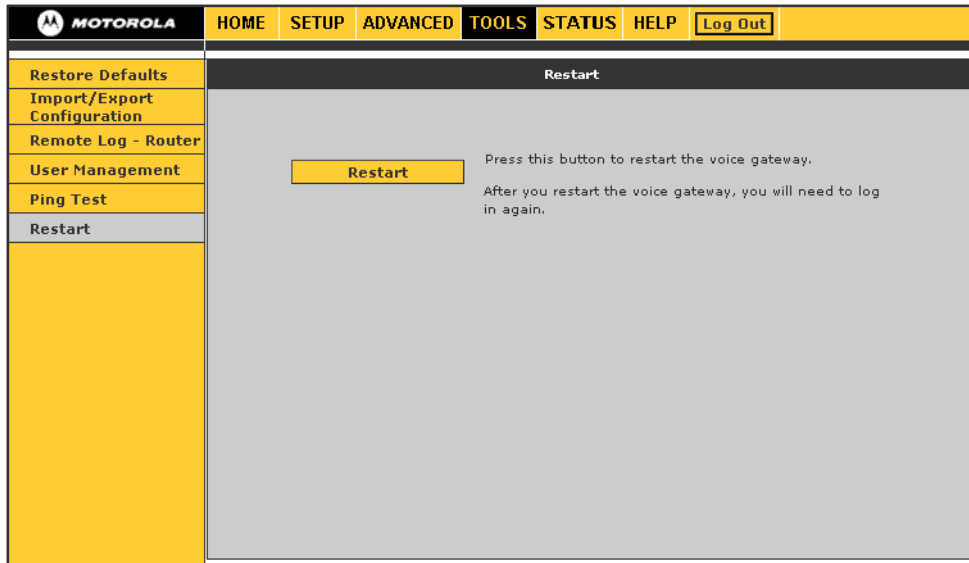

Restart fields

Field	Description
Restart	Restarts the voice gateway. <i>Be sure to save the configuration before you restart.</i> If you restart the voice gateway without saving your changes, it reverts to the previously saved configuration. Your changes are lost. After you restart the voice gateway, you must log in again.

STATUS

The STATUS menu provides links to view the [Network Statistics](#), [Connection Status](#), [DDNS Update Status](#), [DHCP Clients](#), [Product Information](#), and [System Log – Router](#).

The **Refresh** button on every STATUS page, except for Product Information, refreshes the information so it is up to date.

Network Statistics

Use this page to view transmit and receive statistics for the **Ethernet** (local network) or **WAN** (Internet) interfaces.

MOTOROLA		HOME	SETUP	ADVANCED	TOOLS	STATUS	HELP	Log Out
Network Statistics	Network Statistics							
Connection Status	Choose an interface to view your network statistics:							
DDNS Update Status	<input checked="" type="radio"/> Ethernet <input type="radio"/> WAN							
DHCP Clients	Transmit							
Product Information	Good Tx Frames 1011							
System Log - Router	Good Tx Broadcast Frames 3							
	Good Tx Multicast Frames 0							
	Tx Total Bytes 737128							
	Collisions 0							
	Error Frames 0							
	Carrier Sense Errors 0							
	Receive							
	Good Rx Frames 1346							
	Good Rx Broadcast Frames 118							
	Good Rx Multicast Frames 0							
	Rx Total Bytes 137383							
	CRC Errors 0							
	Undersized Frames 0							
	Overruns 0							
	Refresh							

Connection Status

Use this page to view the WAN connection status.

MOTOROLA		HOME	SETUP	ADVANCED	TOOLS	STATUS	HELP	Log Out												
Network Statistics	Connection Status																			
Connection Status	<table border="1"> <thead> <tr> <th>Description</th> <th>Type</th> <th>IP</th> <th>State</th> <th>Online</th> <th>Disconnect Reason</th> </tr> </thead> <tbody> <tr> <td>WAN</td> <td>dhcp</td> <td>NA</td> <td>Not Connected</td> <td>0hr 0min 0sec</td> <td>NA</td> </tr> </tbody> </table>								Description	Type	IP	State	Online	Disconnect Reason	WAN	dhcp	NA	Not Connected	0hr 0min 0sec	NA
Description	Type	IP	State	Online	Disconnect Reason															
WAN	dhcp	NA	Not Connected	0hr 0min 0sec	NA															
DDNS Update Status																				
DHCP Clients																				
Product Information																				
System Log - Router																				
								Refresh												

Connection Status fields

Field	Description
Description	A description of the connection component
Type	The type of component
IP	The IP address of the component
State	The component state — connected or disconnected
Online	The amount of time it has been connected
Disconnect Reason	The reason it was disconnected

DDNS Update Status

The voice gateway DDNS client is disabled by default. When the DDNS client is enabled, it updates every time the voice gateway gets a new IP address.

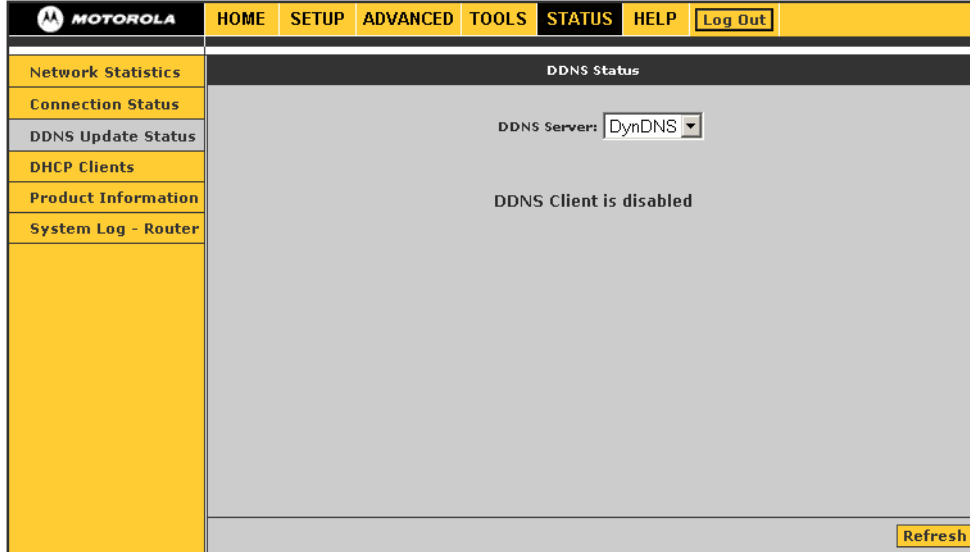

DDNS Status fields

Field	Description
-------	-------------

DDNS Server	Sets the DDNS server — DynDNS or TZO
Status	It can be <i>one</i> of: <ul style="list-style-type: none"> • Updated — the IP address of the client has been changed and an update has been sent to the DDNS server • No change — the IP address of the client has not been changed • Error — there is an error with the DDNS update
Error	If the Status is Error, displays a description of the error.

DHCP Clients

Use this page to view the list of LAN DHCP client devices.

MOTOROLA	HOME	SETUP	ADVANCED	TOOLS	STATUS	HELP	Log Out								
Network Statistics	DHCP Clients														
Connection Status	<table border="1"> <thead> <tr> <th>MAC Address</th> <th>IP Address</th> <th>Host Name</th> <th>Lease Time</th> </tr> </thead> <tbody> <tr> <td>00:01:02:cf:5b:3f</td> <td>192.168.15.2</td> <td>mg</td> <td>0 days 0:45:44</td> </tr> </tbody> </table>							MAC Address	IP Address	Host Name	Lease Time	00:01:02:cf:5b:3f	192.168.15.2	mg	0 days 0:45:44
MAC Address	IP Address	Host Name	Lease Time												
00:01:02:cf:5b:3f	192.168.15.2	mg	0 days 0:45:44												
DDNS Update Status															
DHCP Clients															
Product Information															
System Log - Router															
							Refresh								

Product Information

Use this page to view product hardware and software information, such as model number, hardware revision, and the software and boot loader versions.

MOTOROLA	HOME	SETUP	ADVANCED	TOOLS	STATUS	HELP	Log Out
Network Statistics	Product Information						
Connection Status							
DDNS Update Status							
DHCP Clients							
Product Information	<p>Product Information</p> <p> Model Number TNETV1060SDB_WR HW Revision Unknown Serial Number 159303521702370401010000 Ethernet MAC 00:12:25:D5:C9:C2 </p> <p>Software Versions</p> <p> Gateway 11.1.0-r050919 Boot Loader 1.3.3.1101 </p>						
System Log - Router							
							Refresh

❖ Configuring TCP/IP

All client computers on your network must be configured for [TCP/IP](#) (the protocol that controls communication among computers). Perform *one* of:

- [Configuring TCP/IP in Windows 95, Windows 98, or Windows Me](#)
- [Configuring TCP/IP in Windows 2000](#)
- [Configuring TCP/IP in Windows XP](#)
- Follow the instructions in your Macintosh or UNIX user manual

After configuring TCP/IP, on all computers, perform *one* of the following to verify its [IP address](#):

- [Verifying the IP Address in Windows 95, Windows 98, or Windows Me](#)
- [Verifying the IP Address in Windows 2000 or Windows XP](#)
- Follow the instructions in your Macintosh or UNIX user manual

Configuring TCP/IP in Windows 95, Windows 98, or Windows Me

- 1 On the Windows Desktop, click **Start**.
- 2 Select **Settings** and then **Control Panel** from the pop-up menus to display the Control Panel window:

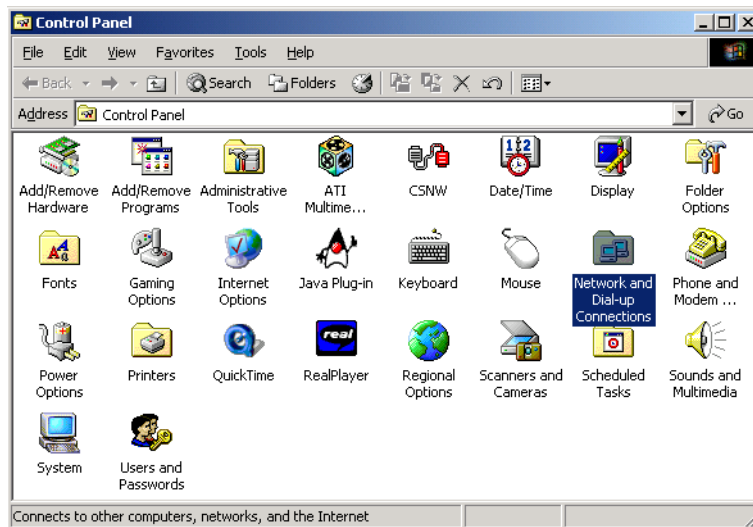

- 3 Double-click the **Network and Dial-Up Connections** icon to display the Network window:

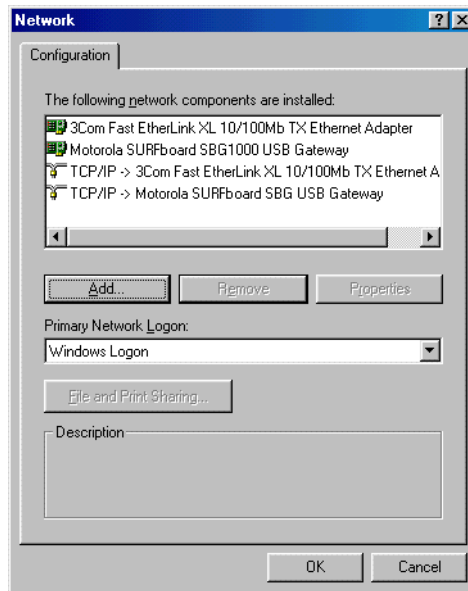

Although your VT model number may be different than in the images in this guide, the procedure is the same.

- 4 Verify that TCP/IP is installed for the adapter used to connect to the VT2442. If TCP/IP is installed, skip to step 9. If TCP/IP is not installed for the adapter, continue with step 5.
- 5 Select the adapter to use for the VT2442 connection and click **Add**. The Select Network Component Type window is displayed:

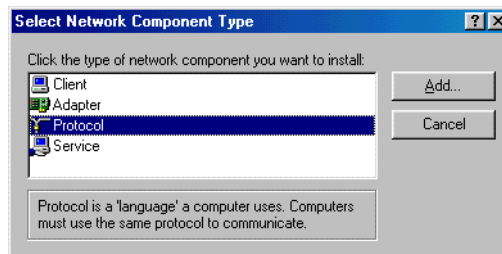

- 6 Click **Protocol** and click **Add**. The Select Network Protocol window is displayed:

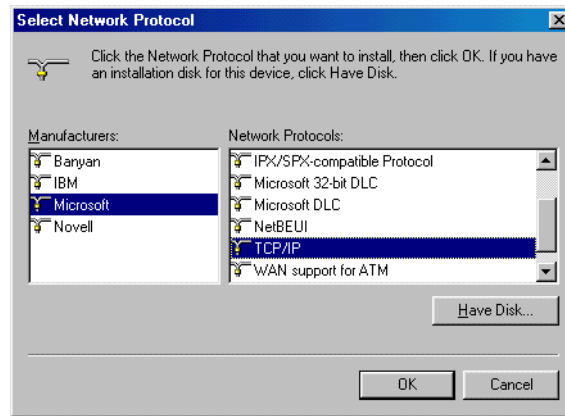

- 7 Click **Microsoft** in the Manufacturers section and click **TCP/IP** in the Network Protocols section.
- 8 Click **OK**.
- 9 Click **TCP/IP** on the Network window. If there is more than one TCP/IP entry, choose the one for the Ethernet card connected to the VT2442.
- 10 Click **Properties**. The TCP/IP Properties window is displayed:

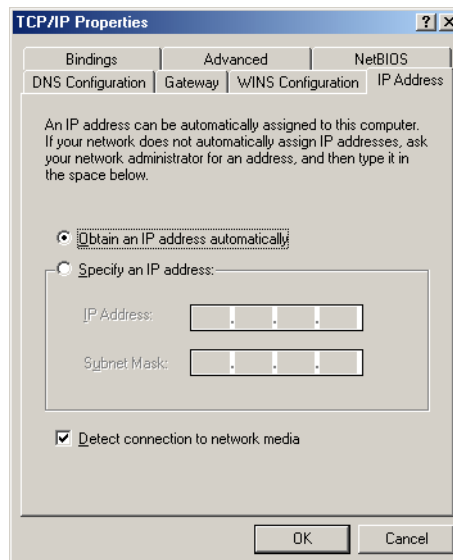

- 11 Click the **IP Address** tab.
- 12 Click **Obtain an IP address automatically**.
- 13 Click **OK** to accept the TCP/IP settings.
- 14 Click **OK** to close the Network window.
- 15 Click **OK** when prompted to restart the computer and click **OK** again.

When you complete TCP/IP configuration, go to [“Verifying the IP Address in Windows 95, Windows 98, or Windows Me”](#) on page 63.

Configuring TCP/IP in Windows 2000

- 1 On the Windows Desktop, click **Start**.
- 2 Select **Settings** and then **Control Panel** from the pop-up menus to display the Control Panel window:

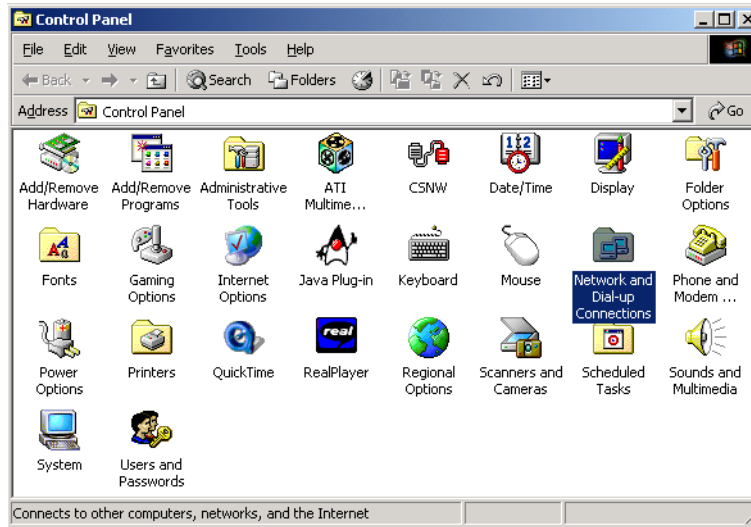

- 3 Double-click the **Network and Dial-up Connections** icon to display the Network and Dial-up Connections window:

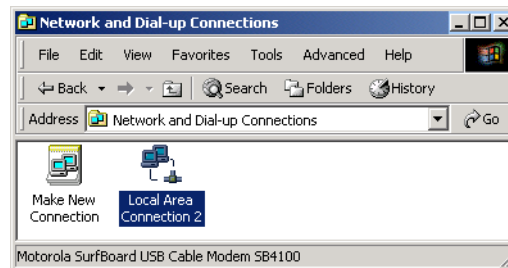

In the steps that follow, a connection *number* like 1, 2, 3, etc., is a reference that is displayed on computers with multiple network interfaces. Computers with only one network interface may only see the label: Local Area Connection.

- 4 Click **Local Area Connection number**. The value of *number* varies from system to system. The Local Area Connection *number* Status window is displayed:

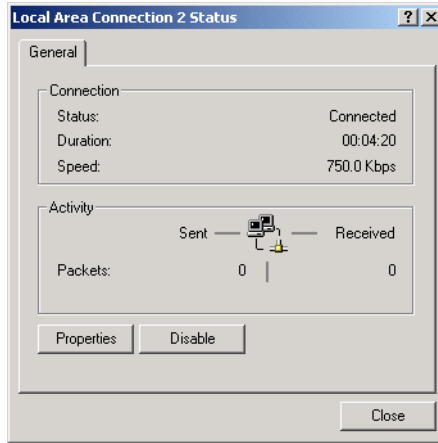

- 5 Click **Properties**. Information similar to the following window is displayed:

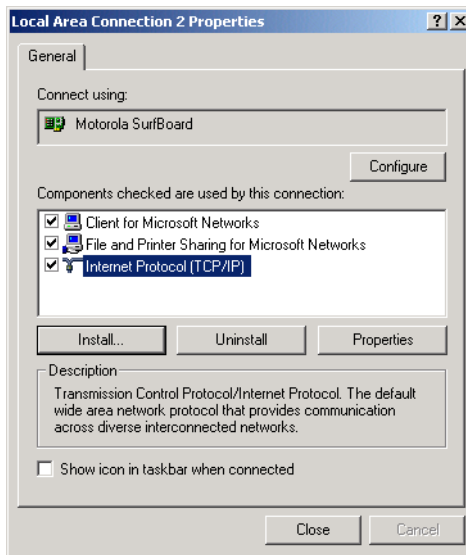

- 6 If Internet Protocol (TCP/IP) is in the list of components, TCP/IP is installed. You can skip to step 10.
- If Internet Protocol (TCP/IP) is not in the list, click **Install**. The Select Network Component Type window is displayed:

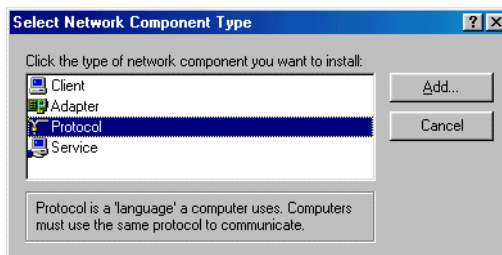

- 7 Click **Protocol** on the Select Network Component Type window and click **Add**. The Select Network Protocol window is displayed:

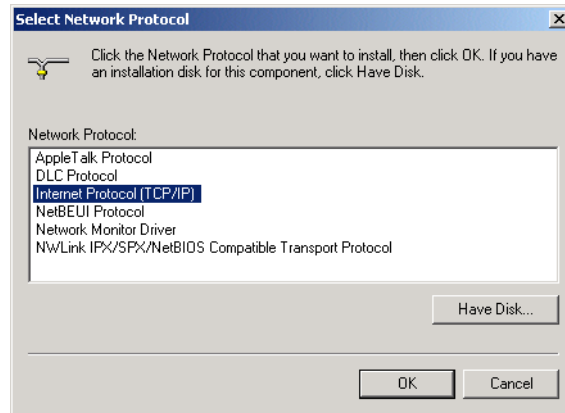

- 8 Click **Internet Protocol (TCP/IP)**.
- 9 Click **OK**. The Local Area Connection *number* Properties window is re-displayed.
- 10 Be sure the box next to Internet Protocol (TCP/IP) is checked.
- 11 Click **Properties**. The Internet Protocol (TCP/IP) Properties window is displayed:

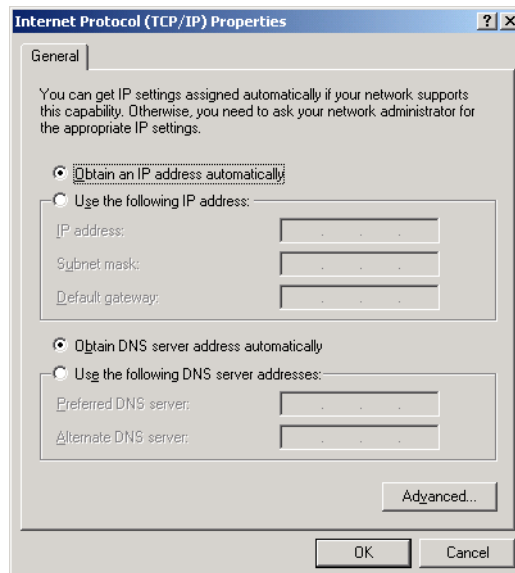

- 12 Be sure **Obtain IP address automatically** and **Obtain DNS server address automatically** are selected.
- 13 Click **OK** to accept the TCP/IP settings.
- 14 Click **Close** to close the Local Area Connection *number* Properties window.
- 15 Click **OK** when prompted to restart the computer and click **OK** again.

When you complete the TCP/IP configuration, go to [“Verifying the IP Address in Windows 2000 or Windows XP”](#) on page 64.

Configuring TCP/IP in Windows XP

- 1 On the Windows desktop, click **Start** to display the Start window:

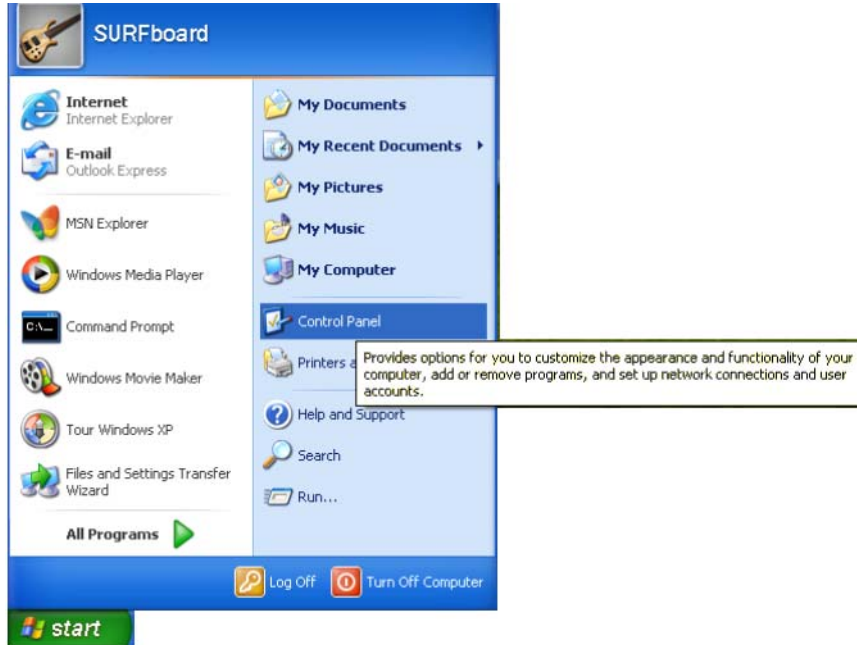

- 2 Click **Control Panel** to display the Control Panel window. The display varies, depending on your Windows XP view options. If the display is a Category view as shown below, continue with step 3. Otherwise, skip to step 5.

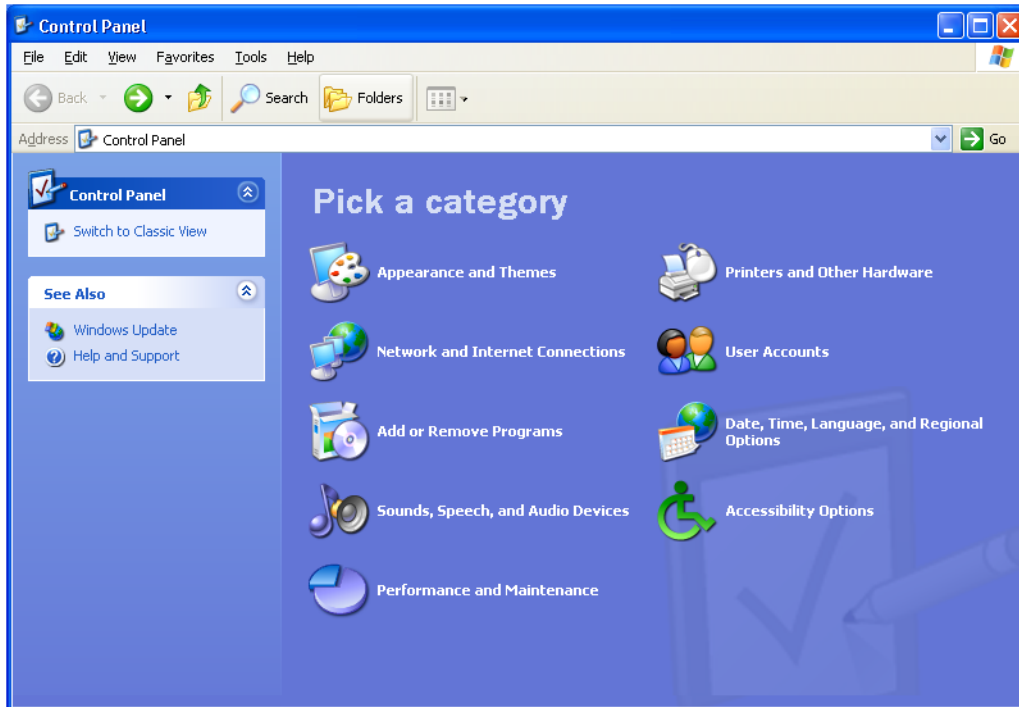

- Click **Network and Internet Connections** to display the Network and Internet Connections window:

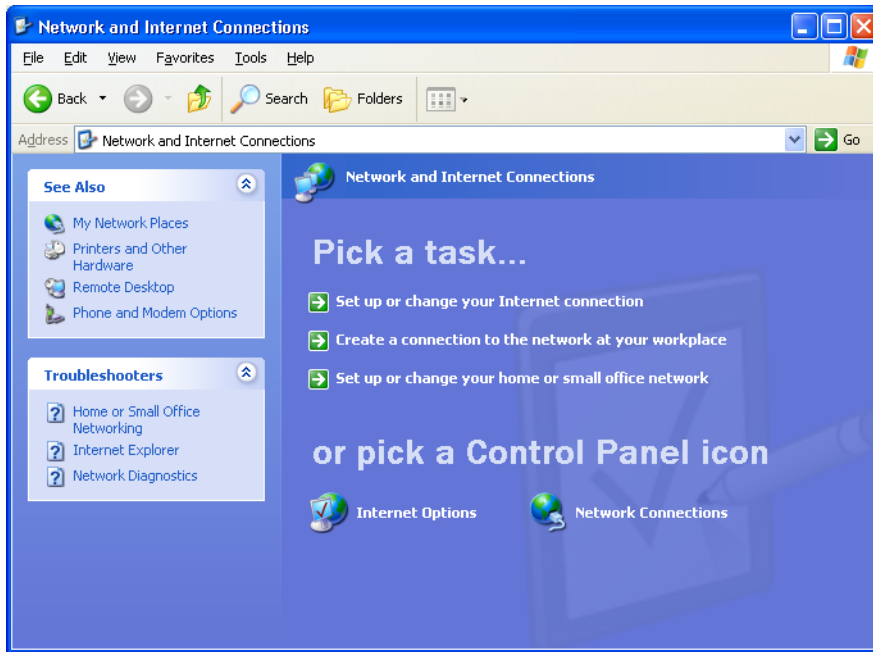

- Click **Network Connections**. Skip to step 6.
- If a classic view similar to below is displayed, double-click **Network Connections** to display the LAN or High-speed Internet connections.

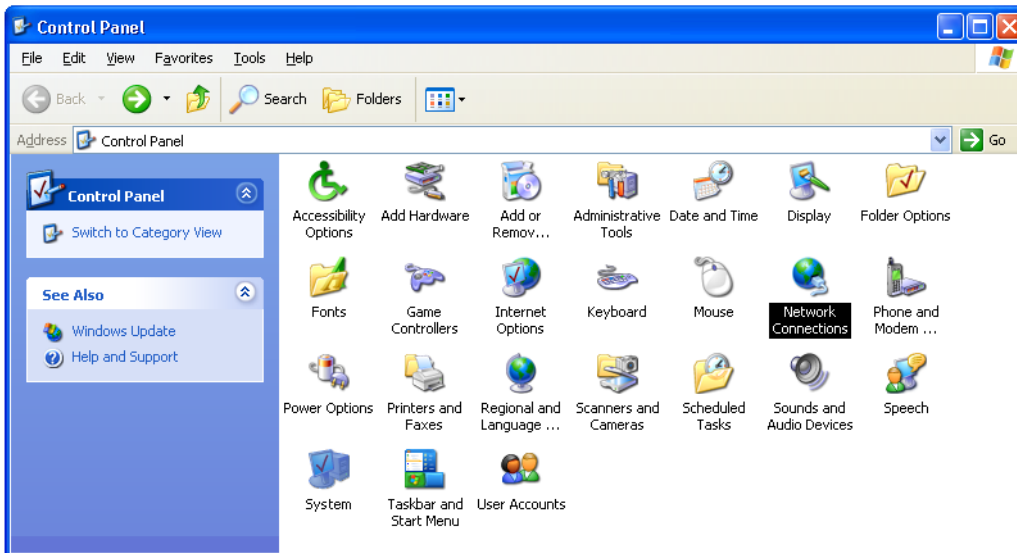

- 6 Right-click the Local Area Connection. If more than one connection is displayed, be sure to select the one for your network interface.

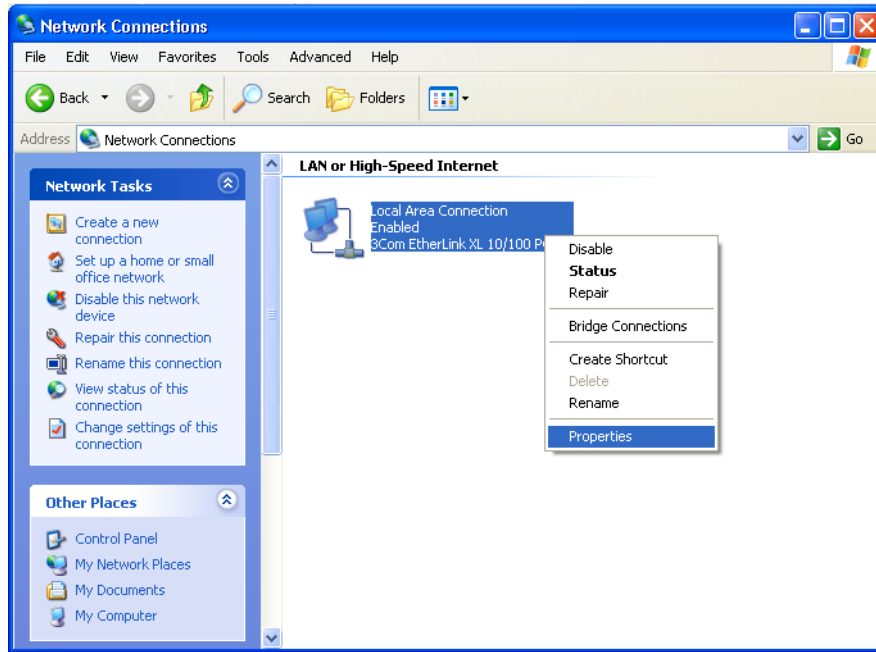

- 7 Select **Properties** from the pop-up menu to display the Local Area Connection Properties window:

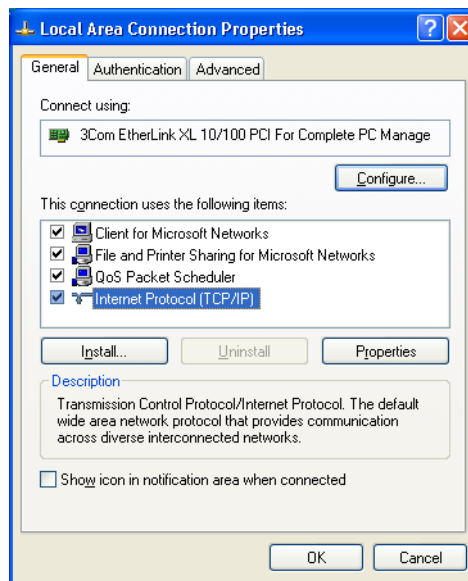

- 8 On the Local Area Connection Properties window, select **Internet Protocol (TCP/IP)** if it is not selected.

- 9 Click **Properties** to display the Internet Protocol (TCP/IP) Properties window:

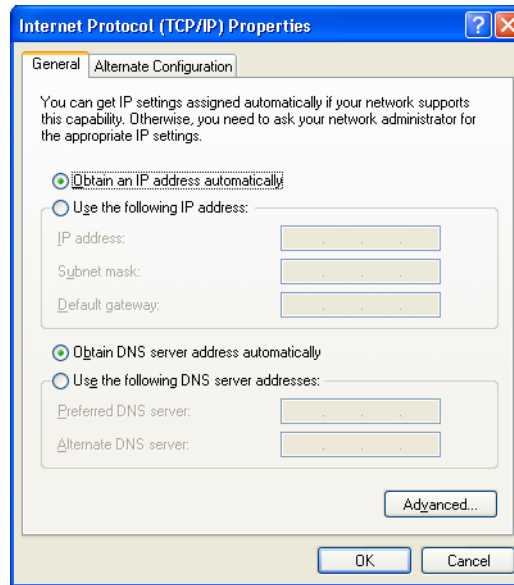

- 10 Be sure **Obtain IP address automatically** and **Obtain DNS server address automatically** are selected.

- 11 Click **OK** to close the TCP/IP Properties window.

- 12 Click **OK** to close the Local Area Connection Properties window.

When you complete the TCP/IP configuration, go to [“Verifying the IP Address in Windows 2000 or Windows XP”](#) on page 64.

Verifying the IP Address in Windows 95, Windows 98, or Windows Me

To check the IP address:

- 1 On the Windows Desktop, click **Start**.
- 2 Select **Run**. The Run window is displayed.
- 3 Type **wiipcfg.exe** and click **OK**. The IP Configuration window is displayed. The Ethernet Adapter Information fields will vary depending on the system, as shown in the following examples:

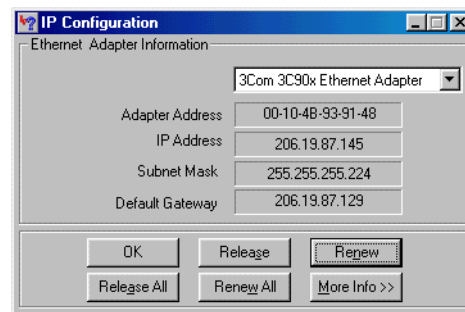
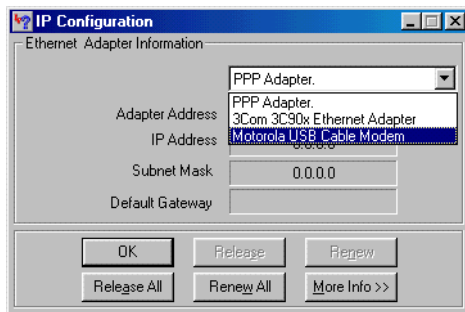
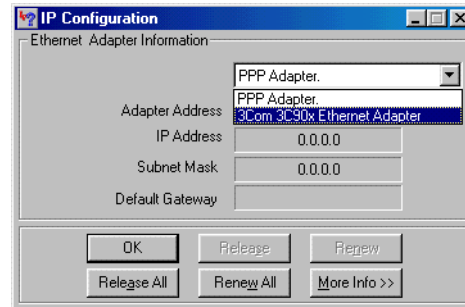
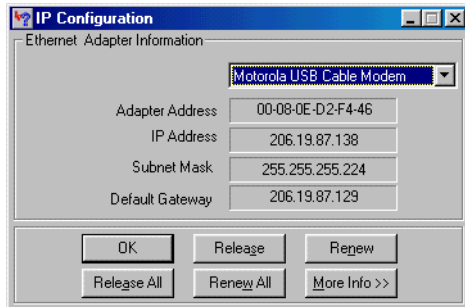

In Windows 98, if "Autoconfiguration" is displayed before the IP Address as in the following example, call your service provider.

Adapter Address	00-80-C6-E7-59-E6
IP Autoconfiguration Address	169.254.191.251

- 4 Select the adapter name (the Ethernet card).
- 5 Click **Renew**.
- 6 Click **OK** after the system displays an IP address.

If after performing this procedure the computer cannot access the Internet, call your cable provider for help.

Verifying the IP Address in Windows 2000 or Windows XP

To check the IP address:

- 1 On the Windows Desktop, click **Start**.
- 2 Select **Run**. The Run window is displayed.
- 3 Type **cmd** and click **OK** to display a command prompt window.
- 4 Type **ipconfig** and press **ENTER** to display the IP configuration. A display similar to the following indicates a normal configuration:

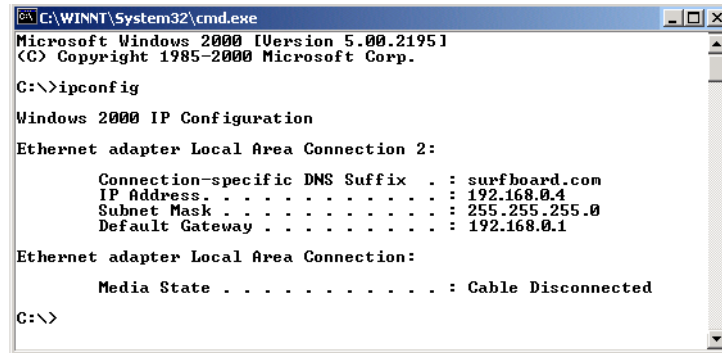

If an Autoconfiguration IP Address is displayed as in the following window, there is an incorrect connection between the PC, the VT2442, and the Internet:

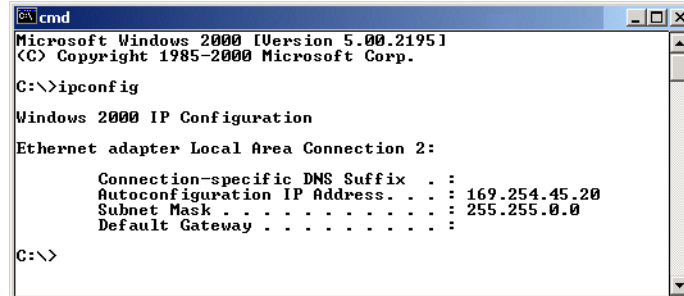

- 5 After verifying your connections, type **ipconfig /renew** and press **ENTER** to renew the IP address. If a valid IP address is displayed as shown, Internet access should be available.

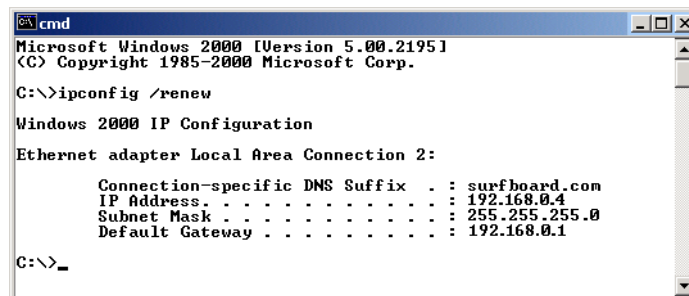

- 6 Type **exit** and press **ENTER** to return to Windows.

If after performing this procedure the computer cannot access the Internet, call your cable or DSL provider for help.

Troubleshooting

If the solutions listed here do not solve your problem, for more troubleshooting help contact Vonage as described in [“Contact Us”](#) on page 68.

Problem

Possible Solutions

Power light is off

Check that the AC power adapter is properly plugged into the electrical outlet and the VT2442.

Check that the electrical outlet is working.

Cannot send or receive data or phone calls or No dial tone

If you subscribed to just one phone line from Vonage, be sure your phone is connected to the **Phone 1** port on the VT2442.

Check all other cabling between the modem, the VT2442, and the computer. Be sure you used the cables provided with the VT2442. All Ethernet cables must be straight-through cables.

Check the lights on the [Front Panel](#) (see page 3).

Check the lights on the modem front panel. For information, see your cable or DSL modem user guide.

If you have only one phone line, be sure your phone is plugged into the green phone port 1 on the VT2442.

Can you access Web pages? If not, check to see whether your ISP (cable or DSL) is having connection issues in your area.

Be sure the telephone connected to the VT2442 is disconnected from the wall jacks that traditional phone companies use. If not, the VT2442 cannot connect with the Vonage server and you will not get a dial tone.

Compare your device connections to those shown in [“Installation With an Existing Router”](#) on page 7 or [“Installation With a Standard Modem”](#) on page 9.

The order in which you turn the devices on is very important. Try the procedure for [“Resetting All of Your Equipment”](#) on page 66.

A computer cannot send or receive data

Check that the Ethernet cable is properly connected to the VT2442 and the computer.

If you have a cable modem *only*, check that your TV is working and the picture is clear. If you cannot receive TV channels, your cable data service will not function. Contact your cable provider.

If you have a DSL modem *only*, check that your DSL service is working. Contact your DSL provider.

My high-speed Internet connection uses a USB port, not an Ethernet port

You need to switch your high-speed Internet connection from USB to Ethernet to use Vonage Internet Phone Service. If your computer does not have an Ethernet [adapter](#), you can purchase an Ethernet adapter or a USB to Ethernet Converter to connect your computer to the VT2442, and ultimately the Internet.

Resetting All of Your Equipment

You can resolve many installation issues by resetting all of your equipment.

To reset all of your equipment:

- 1 Turn off your computer, VT2442 voice gateway, router (if you have one), and DSL or cable modem.
- 2 Turn the devices back on, one at a time, in this order:
 - Modem
 - Router (if present)
 - VT2442
 - Computer

Replacing an Existing Router with the VT2442

You can connect up to four computers directly to the VT2442 Ethernet ports. *It may be easiest to have only a single router — the one built in to your VT2442 — on your home network.*

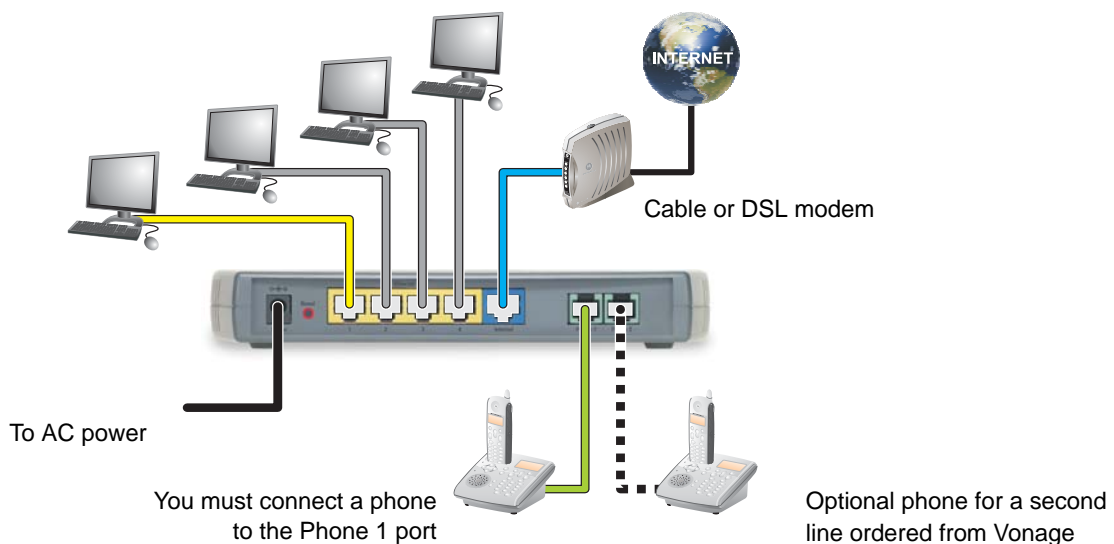

- 1 Shut down your computers properly. Follow the instructions provided with the computers.
- 2 Unplug your cable or DSL modem power cord or adapter.
- 3 Unplug your router.
- 4 Disconnect any cables connecting your router to the modem. Please leave your modem connected to the cable or phone line that provides your Internet connection.

Hint: Your modem should remain off for about 10 minutes to “clear its memory” so it can recognize the VT2442 when you turn it back on. You can continue with the installation during this time.

- 5 Disconnect any cables connecting your computers to the router.
- 6 Connect one end of the blue Ethernet cable to the Ethernet port on your modem.
- 7 Connect the other end of the blue Ethernet cable to the blue Ethernet port labeled **Internet** on the rear panel of your voice gateway.

If you connect the VT2442 directly to your cable or DSL modem, it can prioritize voice calls over data traffic to help ensure high-quality phone service.

- 8 Connect one end of the yellow Ethernet cable to the **Ethernet 1** port on your voice gateway.
- 9 Connect the other end of the yellow Ethernet cable to the Ethernet port on one computer.
- 10 Connect your other computers.

Hint: If you add more than four computers, you can connect your old router or a hub to *one* of Ethernet ports 2, 3, or 4 on the VT2442 and connect your remaining computers to the router or hub. *Be sure only one DHCP server is running on your network. For more information, see "LAN Configuration" on page 20.*

- 11 Continue with step 8 in "[Installation With a Standard Modem](#)" on page 9.



Contact Us

If you have questions about your Vonage Internet phone service:

- In the USA, visit www.vonage.com/help

For information about customer service, technical support, or warranty claims, see the Motorola *Regulatory, Safety, Software License, and Warranty Information* card provided with the VT2442.

For answers to typical questions, see “[Frequently Asked Questions](#)” on page 69.

For more information about Motorola consumer cable products, education, and support, visit broadband.motorola.com/consumers.

Frequently Asked Questions

If you do not understand a term or abbreviation, check the [Glossary](#).

Q What does the Motorola VT2442 Voice Gateway do?

- A** The VT2442 Voice Gateway is a stand-alone media terminal adapter (S-MTA) containing a home router:
- As an S-MTA, it converts analog voice signals to and from a standard telephone to digital data that can be transmitted through a broadband connection across the Internet. It provides an alternate means to make voice calls.
 - Its built-in router provides full network connectivity, a firewall, and VPN passthrough.
 - VT2442 prioritizes voice calls to enable simultaneous voice and data communication with no loss of voice call quality. For a description of the VT2442 features, see “[Overview](#)” on page 1.

Q Will the VT2442 Voice Gateway work with a cable modem or DSL modem?

- A** Yes. The VT2442 Voice Gateway supports [DHCP](#), which is specified for [DOCSIS](#)[®] cable modems, and [PPPoE](#), which is used by most DSL providers.

Q Can I operate a virtual private network (VPN) application behind the VT2442?

- A** Yes. The VT2442 Voice Gateway supports [IPSec](#) and [PPTP](#), the most common VPN protocols.

Q Can I play online games through my VT2442?

- A** By default, the voice gateway blocks all unsolicited messages to the computer or local network as a standard security measure. However, for online games that require some unsolicited messages to be transmitted through the voice gateway, you can specify ports and IP addresses on which to allow unsolicited messages. The VT2442 enables you to set up virtual servers or a [DMZ](#).

Q How do I configure the VT2442?

- A** Most people can send and receive calls immediately after completing [Installation](#)! You can configure your home or office network through a GUI using a connected computer configured to obtain its IP address using DHCP. Or, you can configure the computer statically to 192.168.15.xxx (xxx is from 2 to 254), subnet mask 255.255.255.0, and default gateway 192.168.15.1.

Q What is included with the built-in router?

- A** The VT2442 supports a firewall, RIP, port triggers, advanced ALGs such as RSVP, POP3, SNMP, and streaming media. No separate routers are needed.

Q Is any Quality of Service (QoS) implemented on the VT2442 Voice Gateway?

- A** Although VoIP service is typically best-effort, the VT2442 provides upstream voice prioritization to ensure that upstream voice data has priority over other Web data. This ensures good voice quality even during heavy upstream data transfers, such as e-mail synchronization or file sharing.

Glossary

This glossary defines terms and abbreviations used in this manual. To return to your previous page, click the Adobe® Reader® Go to Previous View button.

10/100Base-T	See <i>Ethernet</i> .
adapter	A device or card that connects a computer, printer, or other peripheral device to the network or to some other device. An Ethernet adapter connects a computer to the LAN.
broadband	High-speed telecommunication over a wide range of frequencies, typically 256 Kbps or faster. Broadband enables more information to be transmitted in less time. The most common broadband service types available to homes and small-offices are cable modem and DSL. Both cable modem and DSL are much faster than a traditional dial-up Internet connection.
broadband provider	If you have a cable modem, the cable company from which you subscribe to high-speed data service. If you have a DSL modem, the telephone company from which you subscribe to DSL service.
cable modem	A device enabling a broadband connection to the Internet over cable television lines. It requires a subscription for high-speed data service from your local cable provider.
coaxial cable (coax)	A type of wire consisting of a center wire surrounded by insulation and a grounded shield of braided wire traditionally used mainly to carry cable television signals. The shield minimizes electrical and radio frequency interference.
default gateway	A designated router that forwards all traffic not addressed to a host on the local subnet.
DHCP	<p>A Dynamic Host Configuration Protocol server dynamically assigns IP addresses to client hosts on an IP network. DHCP eliminates the need to manually assign static IP addresses by “leasing” an IP address and subnet mask to each client. It enables the automatic reuse of unused IP addresses.</p> <p><i>The VT2442 can simultaneously be a DHCP client and a DHCP server:</i></p> <ul style="list-style-type: none">• A DHCP server at Vonage headend assigns a WAN IP address to your VT2442.• The VT2442 contains a built-in DHCP server that assigns private IP addresses to each computer on its LAN.
DMZ	A “de-militarized zone” is one or more hosts logically located between a private LAN and the Internet. A DMZ prevents direct access by outside users to private data. (The term comes from the geographic buffers located between some conflicting countries such as North and South Korea.) In a typical small DMZ configuration, the DMZ host receives requests from private LAN users to access external web sites and initiates sessions for these requests. The DMZ host cannot initiate a session back to the private LAN. Internet users outside the private LAN can access only the DMZ host. You can use a DMZ to set up a web server or for gaming without exposing confidential data.
DOCSIS	The Data-Over-Cable Service Interface Specification define a standard interface for cable modems to deliver data between a cable network and computer systems. Euro-DOCSIS is DOCSIS adapted for use in Europe.
DNS	The Domain Name System is the Internet system for converting domain names to IP addresses. A DNS server contains a table matching domain names such as Internetname.com to IP addresses such as 192.169.9.1. When you access the Web, a DNS server translates the URL displayed on the browser to the destination website IP address. The DNS lookup table is a distributed Internet database; no one DNS server lists all domain-to-IP address matches.
domain name	A unique name, such as motorola.com, that maps to an IP address. Domain names are typically much easier to remember than IP addresses.
dotted-decimal format	<p>Method of representing an IP address or subnet mask using four decimal numbers called octets. Each octet represents eight bits.</p> <p>In a class C IP address, the octets are “network.network.network.host.” The first three octets together represent the network address and the final octet is the host address. In the VT2442 LAN default configuration, 192.168.15 represents the network address. In the final octet, the host address can be from 2 to 254.</p>

download	To copy a file from one computer or other network device to another. You can use the Internet to download files from a server to your home computer. Your voice gateway downloads its configuration file and firmware from Vonage.
downstream	In a cable data or DSL network, the direction of data received by your computer from the Internet.
driver	Software that enables a computer to interact with a network or other device. For example, there are drivers for printers, monitors, graphics adapters, modems, Ethernet, USB, and many others.
DSL	A digital subscriber line enables a broadband connection to the Internet over traditional telephone lines that support DSL. You need a subscription for DSL service from your local telephone company.
dynamic IP address	An IP address that is temporarily leased to a host by a DHCP server. The opposite of <i>static IP address</i> .
Ethernet	The most widely used type of local area network (LAN). The most commonly installed Ethernet networks are called 10Base-T. 10Base-T provides transmission speeds up to 10 megabits per second (Mbps), usually over twisted-pair wire. Fast Ethernet (100Base-T) provides transmission speeds up to 100 Mbps.
F-type connector	A type of connector used to connect coaxial cable to equipment such as the VT2442.
firewall	A security software system on the VT2442 that enforces an access control policy between the Internet and the VT2442 LAN.
flow	A data path moving in one direction.
GUI	graphical user interface
HFC	A hybrid fiber/coaxial cable network uses fiber-optic cable as the trunk and coaxial cable to the subscriber premises.
host	Any computer or similar device supporting end-user applications or services with full two-way network access. Each host has a unique host number that combined with the network number forms its IP address.
hub	On a LAN, a device that connects multiple hosts to the LAN. A hub performs no data filtering. See also <i>router</i> .
IGMP	Internet Group Management Protocol
Internet	A worldwide collection of interconnected networks, all using TCP/IP.
IP	Internet Protocol is a set of standards that enable different types of computers to communicate with one another and exchange data through the Internet. IP provides the appearance of a single, seamless communication system and makes the Internet a virtual network.
IP address	An Internet Protocol address identifies a computer or other device on a TCP/IP network. Networks using the TCP/IP protocol route messages based on the destination IP address.
IPSec	The Internet Protocol Security protocols are authentication and encryption standards for secure data exchange over the Internet.
ISP	Internet service provider
LAN	A local area network provides a full-time, high-bandwidth connection over a limited area, such as a building, campus, office, or home. The computers and other devices you connect to your voice gateway, except for the telephones, form a LAN. Ethernet is the most widely used LAN standard.
MAC address	The Media Access Control address uniquely identifies each device that can be connected to an Ethernet network. It is permanently written to read-only memory (ROM) at the factory and printed on your VT2442.
MHz	Mega hertz. A measure of frequency; one MHz means one million cycles per second.
NAT	Network Address Translation is a standard for a LAN to use one set of IP addresses for internal traffic and a second set of IP addresses for external traffic.
NAPT	Network Address Port Translation is the most common form of translation between public and private IP addresses.
network	Two or more computers connected to communicate with each other. Networks have traditionally been connected using some kind of wiring.
NIC	Network interface card is another name for network adapter. A NIC is installed in an expansion slot or can be built-in. Every Ethernet NIC has a MAC address permanently saved in its ROM.

OOB DTMF	Out-of-Band Dual-Tone Multi-Frequency protocol for voice traffic.
PING	A network utility that tests host reachability by sending a small packet to the host and waiting for a reply. If you PING a computer IP address and receive a reply, you know the computer is reachable over the network. It also stands for "Packet InterNet Groper."
port	On a computer or other electronic device, a port is a socket or plug used to physically connect it to the network or to other devices. In TCP/IP, a port is a number from 0 to 65536 used logically by a client program to specify a server program. Ports 0 to 1024 are reserved.
port triggering	A mechanism that enables incoming communication with specified applications. Primarily used for gaming applications.
POTS	"Plain old telephone service;" basic analog telephone service. POTS uses the lowest 4 kHz of bandwidth on twisted pair wiring.
PPP	Point-to-Point Protocol is a method to establish a network connection or session between hosts.
PPPoE	Point-to-Point Protocol over Ethernet is a specification for connecting to the Internet used with DSL modems.
PPTP	Point-to-Point Tunneling Protocol encapsulates other protocols to create VPNs. It is developed jointly by several vendors.
private IP address	An IP address assigned to a computer on the VT2442 LAN by the DHCP server on the VT2442 for a specified lease time. Private IP addresses are used by the VT2442 LAN only; they are invisible to devices on the Internet. See also <i>public IP address</i> .
PSTN	The public switched telephone network is the traditional circuit-switched, voice-oriented telephone network. See also <i>POTS</i> .
public IP address	A public IP address is visible to devices on the Internet. See also <i>private IP address</i> .
QoS	quality of service
RIP	Routing Information Protocol enables routers to exchange routing information with other network routers. Any RIP-enabled router: <ul style="list-style-type: none">• Sends automatic update packets containing its routing table periodically (every 30 seconds)• Accepts periodic updates from other routers and adds, deletes, or modifies routes in its routing table accordingly• Responds to requests for its routing table
RTP	Real Time Protocol for voice traffic.
RJ-11	The most common type of connector for household or office phones.
RJ-45	The most common type of port for Ethernet networks.
router	On IP networks, a device connecting at least two networks, which may or may not be similar. A router filters data based on the IP address, examining the source and destination IP addresses to determine the best route on which to forward it.
server	A dedicated computer that supplies files, data, or services to other "client" computers or devices.
SIP	Session Initiation Protocol for voice traffic.
S-MTA	A standalone media terminal adapter converts analog voice signals to and from a standard telephone to digital data that can be transmitted through a broadband connection over the Internet.
SSH	secure shell
stateful inspection	A type of firewall that tracks each connection traversing all firewall interfaces to ensure validity. In addition to examining the source and destination in the packet header based on static rules, a stateful inspection firewall: <ul style="list-style-type: none">• Examines packet headers on context established by previous packets that traversed the firewall• Monitors the connection state and saves it in a table• Closes ports until a connection to a specific port is requested• May examine the packet contents up through the application layer to determine more than just the source and destination A stateful-inspection firewall is more advanced than a static filter firewall.

static filter	A type of firewall that examines the source and destination in the packet header based on administrator-defined rules <i>only</i> .
static IP address	An IP address that is permanently assigned to a host. Normally, a static IP address must be assigned manually. The opposite of dynamic IP address.
subnet mask	A bit mask that is logically ANDed with the destination IP address of a packet to determine the network address. A router routes packets using the network address.
subnetwork	A part of a network; commonly abbreviated "subnet." When subnetting is used, the host portion of the IP address is divided into a subnet and host number. Hosts and routers use the subnet mask to identify the bits used for the network and subnet number.
TCP	Transmission Control Protocol provides reliable transport over the network for data transmitted using IP. It defines rules and procedures for data exchange.
TCP/IP	The Transmission Control Protocol/Internet Protocol is a set of protocols that provides rules for communication between networks. It is the worldwide internetworking standard and the basic communications protocol of the Internet.
TFTP	Trivial File Transfer Protocol is a very simple protocol used to transfer files.
UPnP	Universal Plug and Play protocol.
UPS	A universal power supply provides battery back-up for a specified time during a power outage.
upstream	In a cable data or DSL network, the direction of data sent from your computer to the Internet.
USB	Universal Serial Bus
wireless access point (WAP)	A device that provides network connectivity to one or more client computers using radio signals over a wireless connection. One example you could use with your voice gateway is the Motorola Wireless Access Point WA840G .
VoIP	Voice over Internet Protocol is a method to exchange voice, fax, and other information over the Internet. Voice and fax have traditionally been carried over telephone lines using a dedicated circuit for each line. VoIP enables calls to travel as discrete data on shared lines.
VoIP provider	The company from which you purchase VoIP telephone service.
VPN	A virtual private network is a private network that uses "virtual" connections (tunnels) routed over a public network (usually the Internet) to provide a secure and fast connection, usually to users working remotely at home or in small branch offices. A VPN connection provides security and performance similar to a dedicated link (for example, a leased line), but at much lower cost.
WAN	A wide-area network provides a connection over a large geographic area, such as a country or the whole world. The bandwidth depends on need and cost, but is usually much lower than for a LAN. For the voice gateway, "WAN" refers to the VoIP and broadband provider networks.
World Wide Web	An interface to the Internet that you use to navigate and hyperlink to information.

❖ Software License

Motorola, Inc., Connected Home Solutions (“Motorola”) 101 Tournament Drive, Horsham, PA 19044

IMPORTANT: PLEASE READ THIS SOFTWARE LICENSE (“LICENSE”) CAREFULLY BEFORE YOU INSTALL, DOWNLOAD OR USE ANY APPLICATION SOFTWARE, USB DRIVER SOFTWARE, FIRMWARE AND RELATED DOCUMENTATION (“SOFTWARE”) PROVIDED WITH MOTOROLA’S VOICE GATEWAY PRODUCT (THE “VOICE GATEWAY PRODUCT”). BY USING THE VOICE GATEWAY PRODUCT AND/OR INSTALLING, DOWNLOADING OR USING ANY OF THE SOFTWARE, YOU INDICATE YOUR ACCEPTANCE OF EACH OF THE TERMS OF THIS LICENSE. UPON ACCEPTANCE, THIS LICENSE WILL BE A LEGALLY BINDING AGREEMENT BETWEEN YOU AND MOTOROLA. THE TERMS OF THIS LICENSE APPLY TO YOU AND TO ANY SUBSEQUENT USER OF THIS SOFTWARE.

IF YOU DO NOT AGREE TO ALL OF THE TERMS OF THIS LICENSE (I) DO NOT INSTALL OR USE THE SOFTWARE AND (II) RETURN THE VOICE GATEWAY PRODUCT AND THE SOFTWARE (COLLECTIVELY, “PRODUCT”), INCLUDING ALL COMPONENTS, DOCUMENTATION AND ANY OTHER MATERIALS PROVIDED WITH THE PRODUCT, TO YOUR POINT OF PURCHASE OR SERVICE PROVIDER, AS THE CASE MAY BE, FOR A FULL REFUND.

The Software includes associated media, any printed materials, and any “online” or electronic documentation, as well as any updates, revisions, bug fixes, or drivers obtained by you from Motorola or your service provider. Software provided by 3rd parties may be subject to separate end-user license agreements from the manufacturers of such Software.

The Software is never sold. Motorola licenses the Software to the original customer and to any subsequent licensee for personal use only on the terms of this License. Motorola and its 3rd party licensors retain the ownership of the Software.

You may:

USE the Software only in connection with the operation of the Product.

TRANSFER the Software (including all component parts and printed materials) permanently to another person, but only if the person agrees to accept all of the terms of this License. If you transfer the Software, you must at the same time transfer the Product and all copies of the Software (if applicable) to the same person or destroy any copies not transferred.

TERMINATE this License by destroying the original and all copies of the Software (if applicable) in whatever form.

You may not:

(1) Loan, distribute, rent, lease, give, sublicense or otherwise transfer the Software, in whole or in part, to any other person, except as permitted under the TRANSFER paragraph above. (2) Copy or translate the User Guide included with the Software, other than for personal use. (3) Copy, alter, translate, decompile, disassemble or reverse engineer the Software, including but not limited to, modifying the Software to make it operate on non-compatible hardware. (4) Remove, alter or cause not to be displayed, any copyright notices or startup message contained in the Software programs or documentation. (5) Export the Software or the Product components in violation of any United States export laws.

The Product is not designed or intended for use in on-line control of aircraft, air traffic, aircraft navigation or aircraft communications; or in design, construction, operation or maintenance of any nuclear facility. MOTOROLA AND ITS 3RD PARTY LICENSORS DISCLAIM ANY EXPRESS OR IMPLIED WARRANTY OF FITNESS FOR SUCH USES. YOU REPRESENT AND WARRANT THAT YOU SHALL NOT USE THE PRODUCT FOR SUCH PURPOSES.

Title to this Software, including the ownership of all copyrights, mask work rights, patents, trademarks and all other intellectual property rights subsisting in the foregoing, and all adaptations to and modifications of the foregoing shall at all times remain with Motorola and its 3rd party licensors. Motorola retains all rights not expressly licensed under this License. The Software, including any images, graphics, photographs, animation, video, audio, music and text incorporated therein is owned by Motorola or its 3rd party licensors and is protected by United States copyright laws and international treaty provisions. Except as otherwise expressly provided in this License, the copying, reproduction, distribution or preparation of derivative works of the Software, any portion of the Product or the documentation is strictly prohibited by such laws and treaty provisions. Nothing in this License constitutes a waiver of Motorola’s rights under United States copyright law.

This License and your rights regarding any matter it addresses are governed by the laws of the Commonwealth of Pennsylvania, without reference to conflict of laws principles. THIS LICENSE SHALL TERMINATE AUTOMATICALLY if you fail to comply with the terms of this License.

Motorola is not responsible for any 3rd party software provided as a bundled application, or otherwise, with the Software.

U.S. GOVERNMENT RESTRICTED RIGHTS

The Product and documentation is provided with RESTRICTED RIGHTS. The use, duplication or disclosure by the Government is subject to restrictions as set forth in subdivision (c)(1)(ii) of The Rights in Technical Data and Computer Software clause at 52.227-7013. The contractor/manufacturer is Motorola, Inc., [Connected Home Solutions](#), 101 Tournament Drive, Horsham, PA 19044.

Visit our website at:
www.motorola.com

